



# **MODEL 2040**

## **INSTRUCTION MANUAL**

Read safety instructions carefully and understand them before using.  
Retain this instruction manual for future reference.

Please read this Instruction Manual carefully before using the unit in order to get the most out of it and to enjoy using it for a long time. Please keep this Instruction Manual at hand taking care not to lose it.

**BEFORE OPERATION**

1. Do not operate the machine even for trial before lubricating it.
2. Confirm that the voltage and phase (single or 3-phase) are correct by checking them against the ratings shown on the motor nameplate.
3. When running your machine for the first time after set-up, check the rotational direction of the hand wheel. Turn on the power switch. Run the machine at a low speed while checking the rotational direction of the hand wheel. (The hand wheel should turn counterclockwise as observed from the hand wheel side.)
4. For the first month, run the machine at speed of 500 s.p.m. or less.

**CAUTION**

1. Keep your hands away from the needle when you turn on the power switch or while the machine is operating.
2. During operation, be careful to keep all body parts away from the hand wheel, V-belt, bobbin winder or motor. Also, do not place anything close to them.
3. Do not turn the machine with the finger guard, belt cover or any other protectors removed.
4. Be sure to turn off the power switch and confirm that the motor is completely stopped before removing the V-belt.

**SPECIFICATIONS**

Usage	Bags, Saddles, Bag Handles, Shoes, Safety Belts, Etc
Speed, Max. (SPM)	800
Clearance Under Foot	13/16" (20 mm)
Needle Bar Stroke	2-3/16" (56 mm)
Stitch Length, Max	2-5/8" spi (12 mm)
Needle	794 (DYx3), No.200 (No.130~280)
Work Space	16-1/2" (420 mm)

**To adjust the needle-to-shuttle clearance**

1. Loosen screw (6), (7), (8).
2. Adjust the clearance by moving shuttle driving shaft front bushing (9) to the left and right.
3. After the adjustment has been completed, tighten screw (6), (7), (8) firmly.

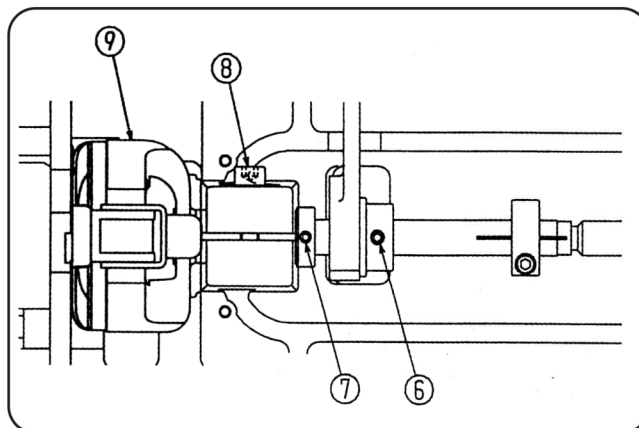

### Clearance between the needle and the shuttle driver

The clearance between the needle and the needle guide of the shuttle driver has already been adjusted to the range of 0 through 0.05mm.

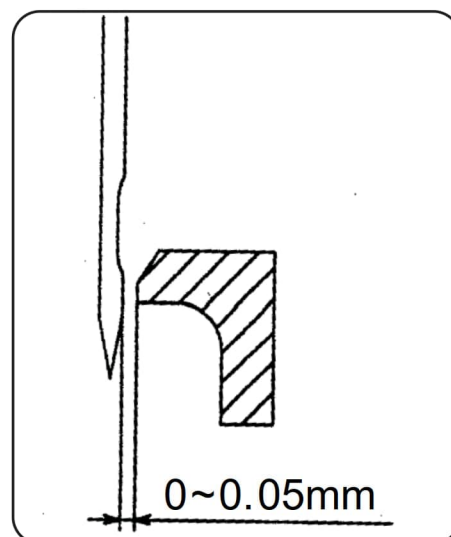

### To adjust the clearance between the needle and the shuttle driver

1. Loosen screws (3), (6), (7).
2. Adjust the clearance by moving shuttle driving shaft (10) to the left and right.
3. After adjustment has been completed, tighten screw (3), (6), (7) firmly.

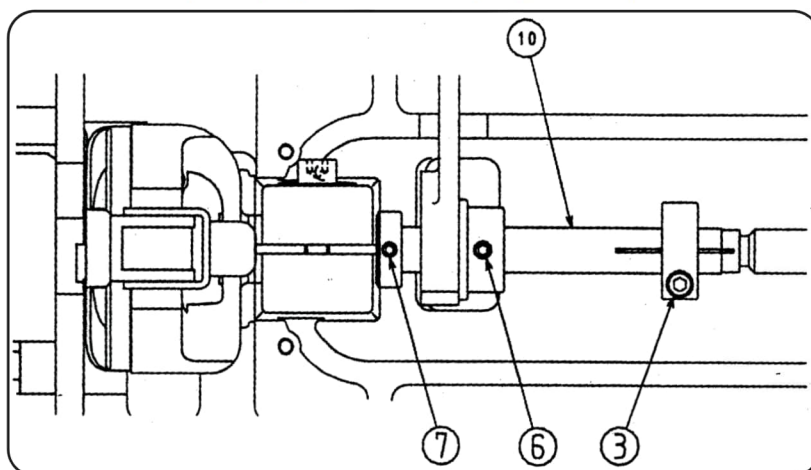

### 1. INSTALLING THE BELT COVER

Attach the belt cover with screws as shown in the figure.

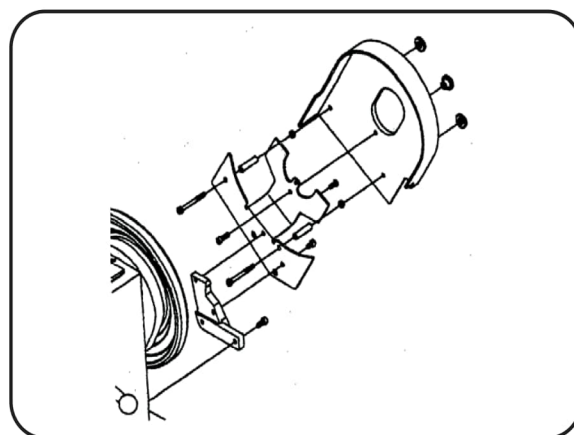

## 2. LUBRICATION

**CAUTION**

TURN THE POWER SUPPLY OFF TO PREVENT UNEXPECTED INJURY. BE SURE TO CONFIRM THE MOTOR HAS COMPLETELY STOPPED ROTATING BEFORE PROCEEDING.

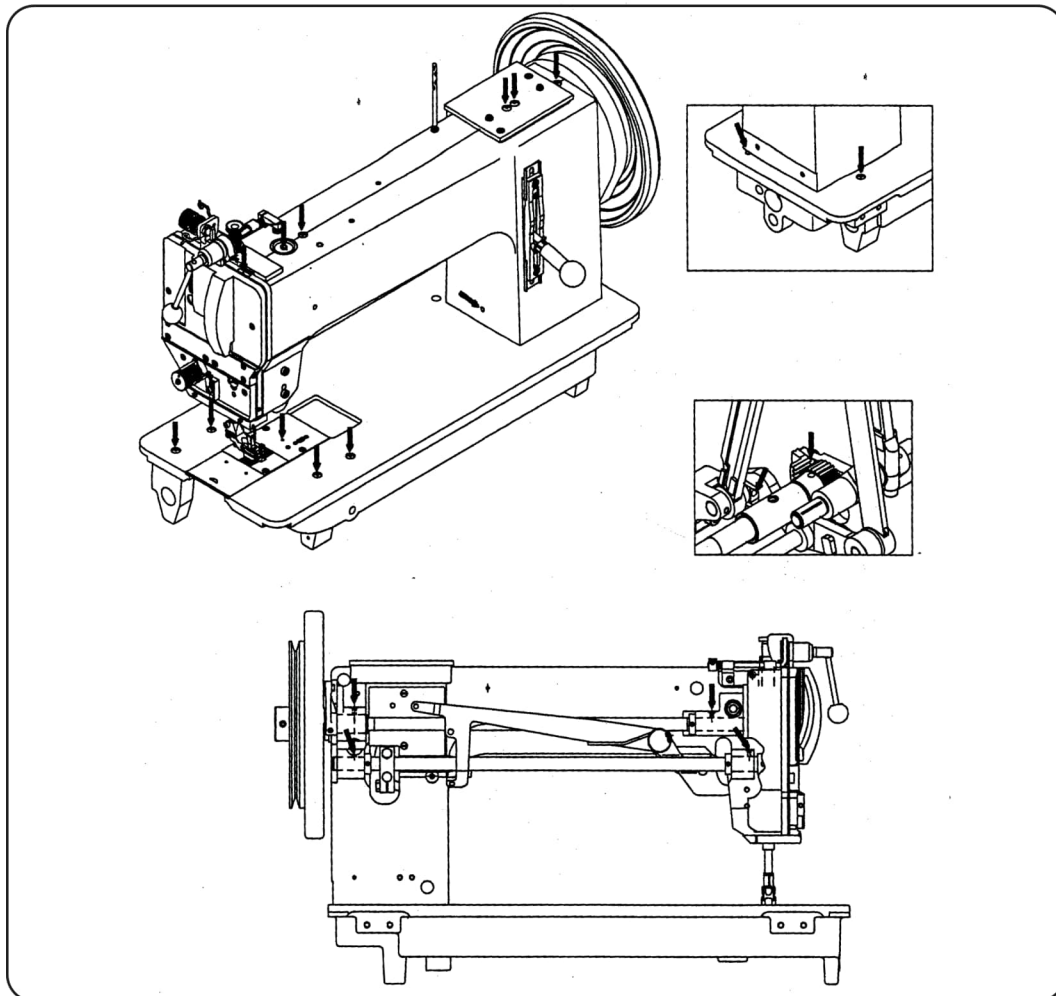

- 1) Uncrate the machine and clean it thoroughly. Add oil to the machine prior to use.
- 2) After oiling all the sections requiring lubrication, wait for approximately 10 minutes so that oil can penetrate each section sufficiently before starting continuous operation.
- 3) When operating the machine continuously, apply two to three drops of oil to each section noted with an arrow mark in the following figure whenever starting operation in the morning and in the afternoon.

## 3. HOW TO INSTALL THE NEEDLE

**CAUTION**

TURN THE POWER SUPPLY OFF TO PREVENT UNEXPECTED INJURY. BE SURE TO CONFIRM THE MOTOR HAS COMPLETELY STOPPED ROTATING BEFORE PROCEEDING.

Be sure to power-off the motor

The normal needle system is a 794 (DYx3).

- 1) Turn the hand wheel by hand and raise the needle bar to its top position.
- 2) Loosen screw (1) and insert the needle (2) into the hole until it will go no further. Insert the needle with its recess (3) facing directly to the right-hand side.

Securely tighten the screw in the needle.

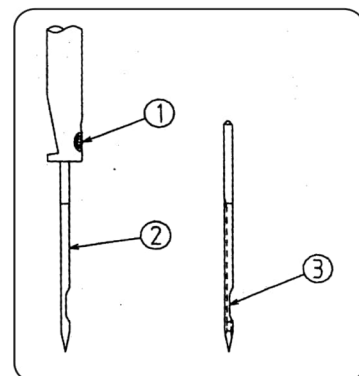

#### 4. HOW TO TAKE OUT THE BOBBIN

CAUTION	TURN THE POWER SUPPLY OFF TO PREVENT UNEXPECTED INJURY. BE SURE TO CONFIRM THE MOTOR HAS COMPLETELY STOPPED ROTATING BEFORE PROCEEDING.
---------	---

- 1) Turn the hand wheel by hand (until the needle bar comes down to the lowest point of its stroke) so that the bobbin case retaining spring (1) in the shuttle body come to recess (A) in the cover of the shuttle race body.

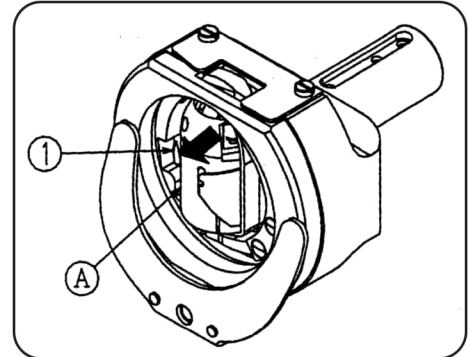

- 2) When the bobbin case retaining spring is pressed, the bobbin case (2) will be opened and the bobbin (3) will pop out of the case.

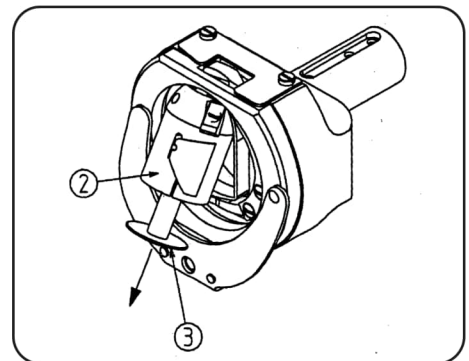

#### 5. HOW TO INSTALL THE BOBBIN

CAUTION	TURN THE POWER SUPPLY OFF TO PREVENT UNEXPECTED INJURY. BE SURE TO CONFIRM THE MOTOR HAS COMPLETELY STOPPED ROTATING BEFORE PROCEEDING.
---------	---

- 1) After pulling out thread approximately 10cm from the bobbin (1), put the bobbin into the bobbin case (2).
- 2) Pass the thread through the threading groove (A) in the bobbin case. (Caution) Fit the bobbin in the bobbin case so that the bobbin turns in the direction of the arrow when the bobbin thread is pulled.
- 3) Pass the thread through thread slit (B) and pull it up. Next the thread can be passed under the thread tension spring (3) and pulled out.
- 4) Push the bobbin case into its original position of holding the bobbin.

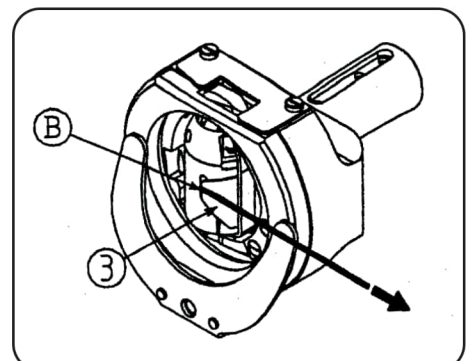
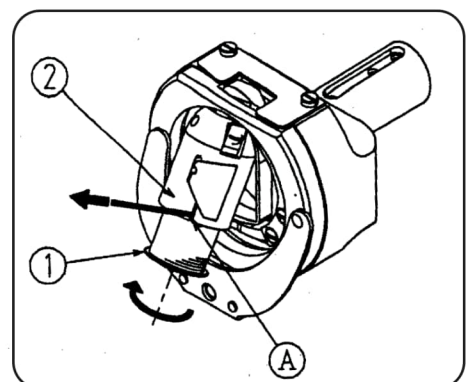

## 6. HOW TO THREAD THE MACHINE HEAD

### CAUTION

TURN THE POWER SUPPLY OFF TO PREVENT UNEXPECTED INJURY. BE SURE TO CONFIRM THE MOTOR HAS COMPLETELY STOPPED ROTATING BEFORE PROCEEDING.

- 1) Turn the hand wheel by hand to move the thread take-up lever to its top position.
- 2) Thread in the order illustrated and thread the needle from the left to the right.
- 3) Pull out the thread, which has been threaded in the needle, approximately 10cm.

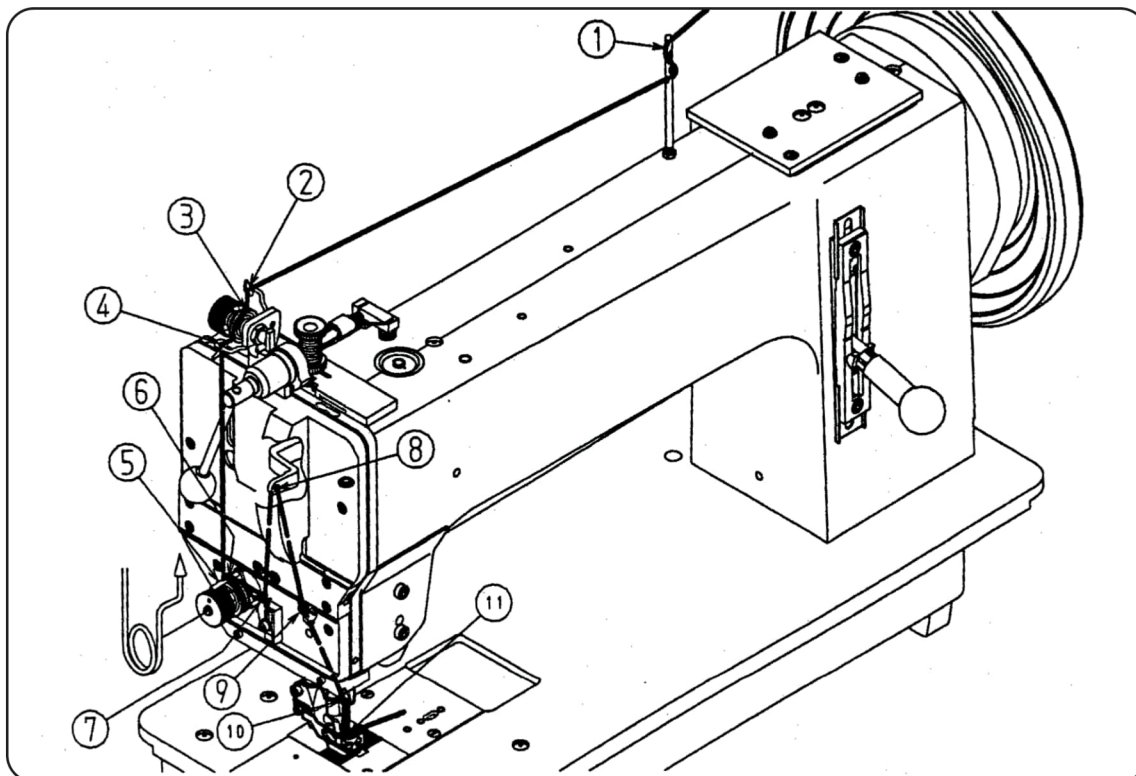

## 7. ADJUSTING THE STITCH LENGTH AND REVERSE STITCHING

### Adjusting the stitch length

To adjusting the stitch length, use the feed regulator grip (1). Align the upper end (A) of the feed lever to the scale indicating the desired amount.

To increase the pitch, turn the grip counterclockwise.

To decrease the pitch, turn the grip clockwise. (To decrease the stitch length, turn the grip while slightly pushing the feed lever down.)

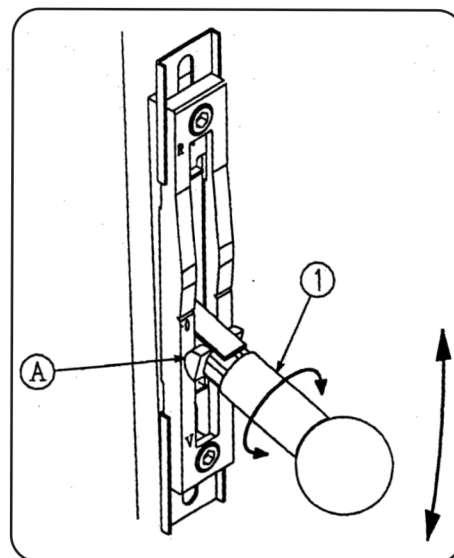

## 8. THREAD TENSION

### CAUTION

TURN THE POWER SUPPLY OFF TO PREVENT UNEXPECTED INJURY. BE SURE TO CONFIRM THE MOTOR HAS COMPLETELY STOPPED ROTATING BEFORE PROCEEDING.

#### Adjusting the needle thread tension

Adjust the needle thread tension by thread tension nut (1).

To increase the needle thread tension, turn the nut clockwise (A).

To decrease the needle thread tension, turn the nut counterclockwise (B).

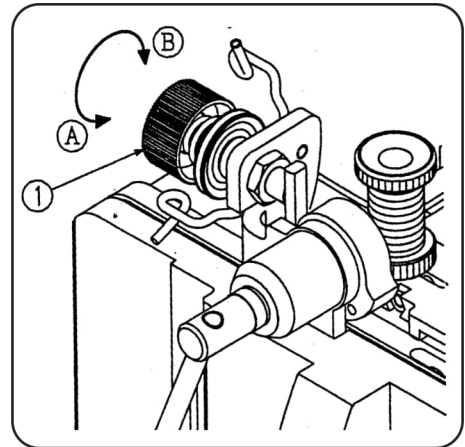

#### Adjusting the bobbin thread tension

To adjust the bobbin thread tension loosen screw (1).

Adjust the bobbin thread tension by turning screw (2).

To increase the bobbin thread tension, turn the screw clockwise (A).

To decrease the bobbin thread tension, turn the screw counterclockwise (B).

After the bobbin thread tension has been adjusted, tighten screw (1) firmly.

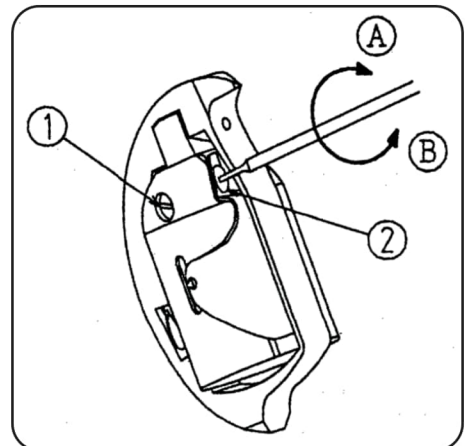

## 9. THE THREAD TAKE-UP SPRING

### CAUTION

TURN THE POWER SUPPLY OFF TO PREVENT UNEXPECTED INJURY. BE SURE TO CONFIRM THE MOTOR HAS COMPLETELY STOPPED ROTATING BEFORE PROCEEDING.

The normal stroke of thread take-up spring (1) is 10 to 14mm.

To adjust the operating range:

- 1) Loosen screw (2).
- 2) Adjust the operating range by moving the take-up spring adjusting plate (3) up and down.
- 3) After adjustment has been completed, tighten screw (2) firmly.

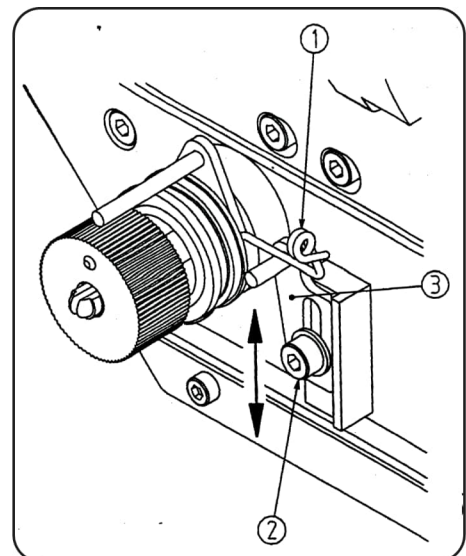

## 10. ADJUSTING THE PRESSER FOOT PRESSURE

### CAUTION

TURN THE POWER SUPPLY OFF TO PREVENT UNEXPECTED INJURY. BE SURE TO CONFIRM THE MOTOR HAS COMPLETELY STOPPED ROTATING BEFORE PROCEEDING.

Normal height of presser spring regulator (1) is 35mm. The intermediate presser foot pressure can be adjusted according to the type of material to be used.

To adjust the presser foot pressure, follow the procedure stated below:

- 1) Loosen the nut of the presser spring regulator (2).
- 2) Turn the regulator (1) clockwise to increase the pressure, or counterclockwise to decrease it.
- 3) After the adjustment, tighten the nut (2) so that the regulator is securely fixed at the proper position.

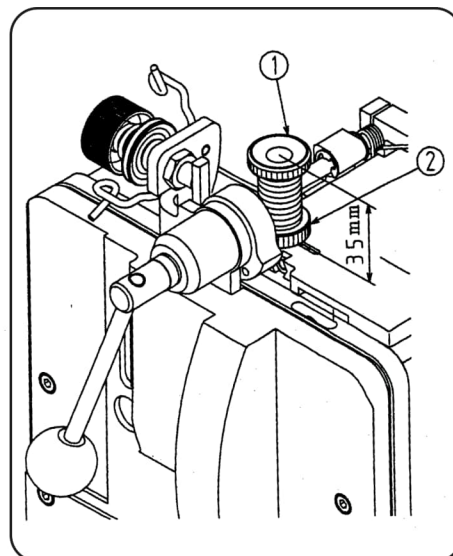

## 11. STROKE HEIGHT OF THE WALKING FOOT

### CAUTION

TURN THE POWER SUPPLY OFF TO PREVENT UNEXPECTED INJURY. BE SURE TO CONFIRM THE MOTOR HAS COMPLETELY STOPPED ROTATING BEFORE PROCEEDING.

The walking foot and presser foot have a maximum stroke of 10mm. The maximum height has been set in the factory.

By varying the thickness of the material (cross-seams) during a sewing run, the presser foot stroke should be adjusted to the thickest material.

To adjust:

- 1) Loosen screw (1).
- 2) Insert screwdriver in the slot of the slider (2) and re-set the slider upwards.

Slider up: minimum stroke

Slider down: maximum stroke

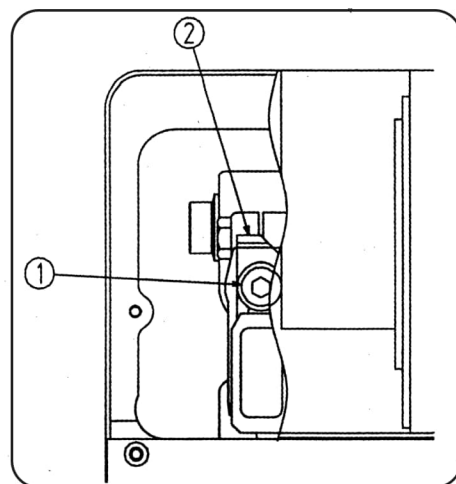



## 12. ADJUSTING THE NEEDLE-TO-SHUTTLE RELATION

**CAUTION**

TURN THE POWER SUPPLY OFF TO PREVENT UNEXPECTED INJURY. BE SURE TO CONFIRM THE MOTOR HAS COMPLETELY STOPPED ROTATING BEFORE PROCEEDING.

**Positioning the needle and shuttle**

Turn the hand wheel to make the needle bar ascend 4mm from its lowest position.

At this time, blade point (1) of the shuttle should be aligned with the center of needle (2).

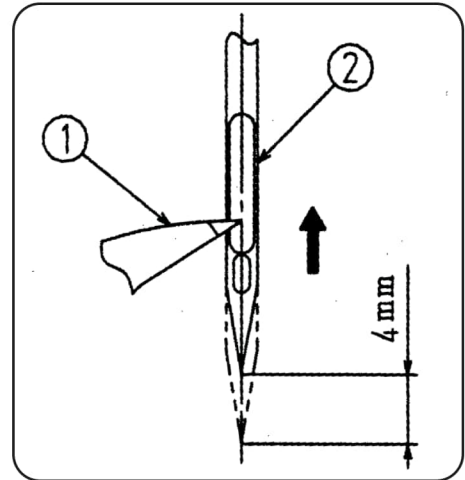

**To adjust the position of the needle and shuttle**

- 1) Loosen screw (3).
- 2) Align the blade point of the shuttle by turning the shuttle by hand.
- 3) After adjustment has been completed, tighten screw (3) firmly.

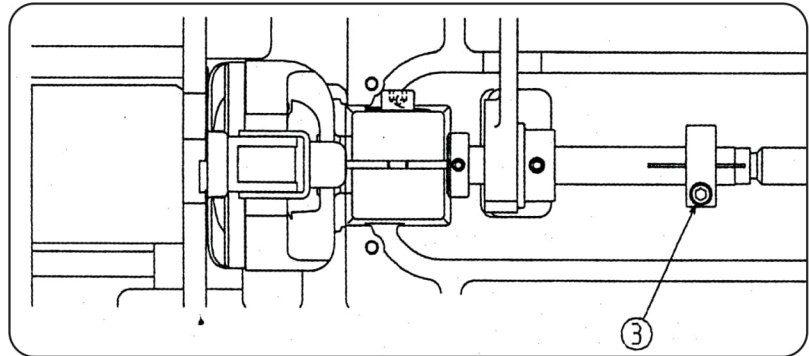

**The height of the needle bar**

The correct height is that the distance from the blade point of the shuttle to the upper end of the needle eyelet is 3.5mm when the blade point of the shuttle is aligned with the center of the needle.

**To adjust the height of the needle bar:**

- 1) Turn the hand wheel and stop turning it when the blade point of the shuttle is aligned with the center of needle.
- 2) Loosen screw (4).
- 3) Adjust the height by moving needle bar (5) up and down.
- 4) After adjustment has been completed, firmly tighten screw (4).

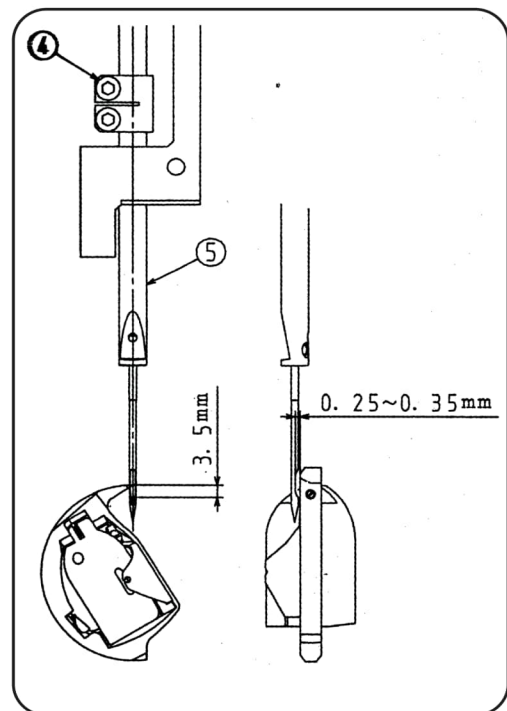

**The needle-to-shuttle clearance**

The clearance between the recess in the needle and the blade point of the shuttle has already been adjusted to 0.25~0.35mm.

[www.consew.com](http://www.consew.com)

**CONSEW**®

Specifications subject to change without notice

© 2023 CONSEW USA