

CONSEW *Since 1898*®

CONSOLIDATED SEWING MACHINE CORP.

└ INDUSTRIAL SEWING & CUTTING EQUIPMENT

MODEL 207-1

**INSTRUCTION
MANUAL AND
PARTS BOOK**

Operation instruction

Warning:

1. All parts designs are subject to revision, and parties to agreements wouldn't be noticed.
2. Non-Professional wouldn't adjust and maintain the machine except adjusting the stitch.

INDEX

1、 Brief introduction	1
2、 Main specification	1
3、 Installation	1
(1). Location of the machine.....	1
(2). Install the arm and oil reservoir.....	1
(3). Install the machine head.....	1
4、 Installing motor	2
5、 Connecting the clutch lever to the pedal	2
6、 Installing the presser foot lift control plate	2
7、 Installing the bobbin winder	3
8、 Installing the thread unwinder	3
9、 Preparation	3
(1). Cleaning the machine.....	3
(2). Examination.....	3
10、 Lubrication	4
11、 Trial run	4
12、 Installing the needle	4
13、 Coordination among the needle,the thread and the material	5
14、 Threading the needle thread	5
15、 Adjusting the tension of bobbin thread and needle thread	5
(1). Adjusting the tension of bobbin thread.....	5
(2). Adjusting the tension of needle thread.....	6
16、 Winding the bobbin thread and adjustment	6
17、 Stitch length and forward and backward feeding	7
18、 Adjusting presser foot pressure	7
19、 The function of the safety clutch and its using	7
20、 Adjusting the timing of feed	8
21、 Adjusting the feed dog height position	8
22、 Adjusting the timing of feed	9
23、 Adjusting the timing of needle and hook	9
24、 The relation between the hook thread sparate bracket	10
25、 Installing the hook	10

1. Brief Introduction

It's designed with sliding lever thread take-up, vertical rotating hook to produce double lockstitch; gear band for driving arm shaft and hook shaft, lever type stitch regulator, compound feed by presser foot, feed dog and needle. And the clutch safe device is installed to prevent the damage. It is easy for sewing more lays leather with high presser foot lift, large stitch length and cylinder bed.

It's widely used for sewing heavy-duty luggage suitcase, seat cushion, especially for cylinder and curve articles.

It's a essential equipment for edge seaming.

3. Installation

(1) Location of the machine

The machine must be located on rigid and flat floor for ensuring its smooth operation and reducing its vibration. Furthermore, a rubber mat should be inserted between the machine stand and the floor for further reducing the running noise.

(2) Install the arm bed and oil reservoir(Fig. 1)

At first, the four screw holes of the arm bed should align the four holes of the table and should be plunged through four bolts and tighten the nut. Then put the oil reservoir on the arm bed smoothly.

(3)Install the machine head(Fig. 2)

At frist, half of the hinges should be made to engage with the arm bed, then put the head lightly on the base of the head and move slightly. The three screw holes of the hinges of the head should be made to align with the three holes of the hinge and three screw will be tighten and fixed.

2. Main specification

Application	Medium, heavy and extra heavy
Max. Sewing speed	2200 s.p.m.
Stitch length	0-5mm
Needle bar stroke	33.2mm
Presser foot lift height	8.5mm by hand
	14mm by knee
Needle	DP×17 18#~23#
Rotating hook	Standard vertical hook
Lubrication	Manual
Motor	370W

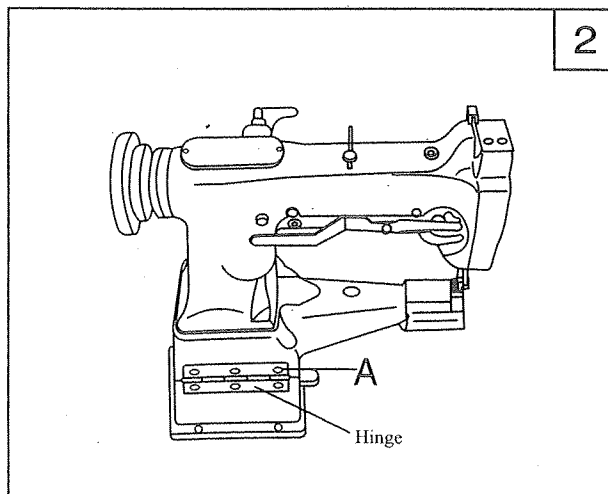
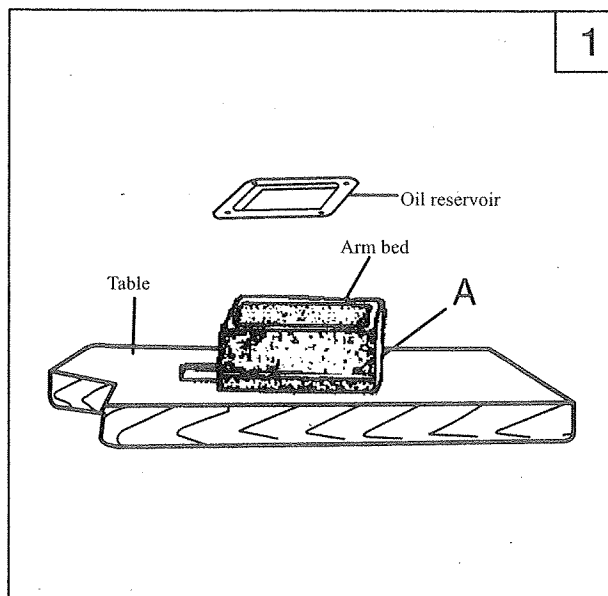

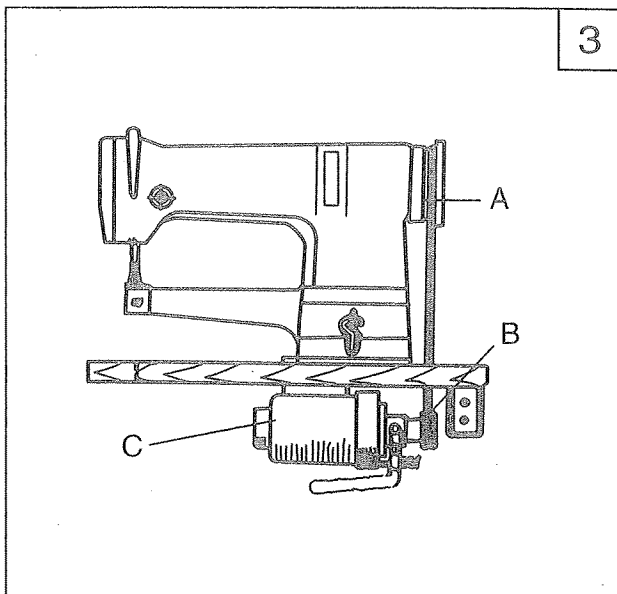

4. Installing the motor (Fig. 3)

Align machine balance wheel belt groove A with motor pulley belt groove B by moving motor C leftward or rightward. Be sure the belt is not touched with the table.

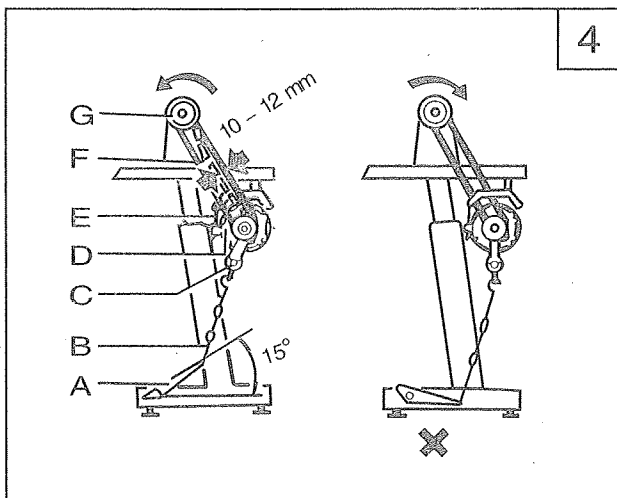

5. Connecting the clutch lever to the pedal (Fig. 4)

- 1) The optimum tilt angle of pedal A against floor is appropriate 15 degree.
- 2) Adjust the E clutch of the motor so that clutch lever C and draw bar B run in one line.
- 3) The machine balance wheel should rotate counter-clockwise for normal sewing when observed from opposite side of the balance wheel. The motor rotates in the same direction. The rotation can be reversed by reversing the plug of the motor.
- 4) Adjust the tension of V-belt F by moving vertically. The proper tension of V-belt is a slack of 10-12mm when the belt is depressed by forefinger.

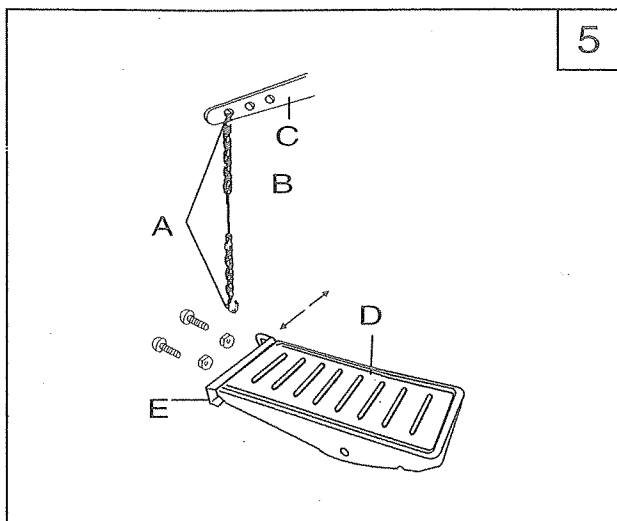

6. Installing the presser foot lift control plate(Fig. 5)

At first, the hook A should be connected to the chain B and presser foot lift lever C, then put the pedal complete D on the stand. And move the control plate E leftward or rightward until the chain becomes on one line. Tighten the bolts and nuts, finally, connect the finger to the control plate.

7. Installing the bobbin winder(Fig. 6)

Align pulley B of the bobbin winder with the outside of the belt C. And there should be a proper clearance between them, so that pulley B can be contacted with the belt when latch thumb lever A is depressed, thereby the belt can drive pulley B while the machine running. The bobbin winder should be parallel with belt slit E of the table, then fasten two wood screws D.

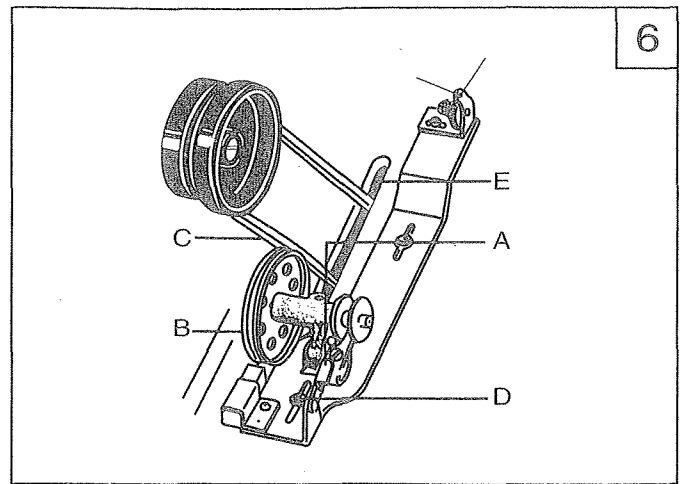

8. Installing the thread unwinder (Fig. 7)

The thread unwinder should be located on the right backside of the table. Threading should be smooth when sewing. And the spool rest may not be obstructed when the machine head is turned backward, then tighten wood screw C.

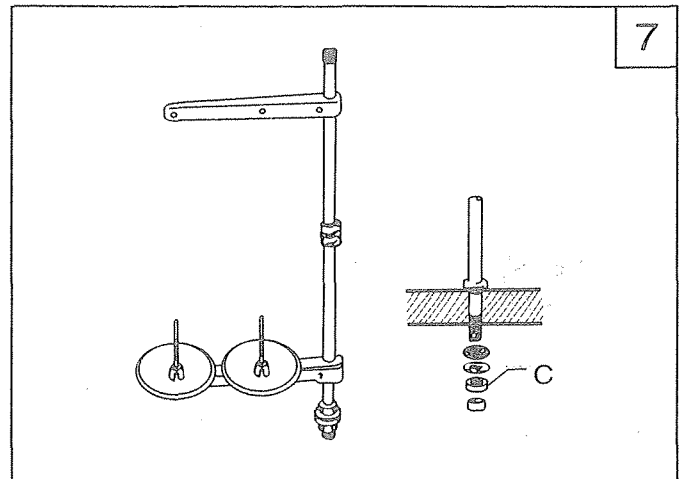

9. Preparation

(1) Cleaning the machine

Before the head is packed, all the parts of the machine are coated with preventive grease, meanwhile the hardened grease and converged dust on the machine surface during long storage and shipment must be removed by clean cloth with gasoline.

(2) Examination

The parts of the machine may be loose and deformed after long distance transportation with jolt though every machine is confirmed by strict inspection and test before delivery. A thorough examination must be performed after cleaning the machine. Turn the balance wheel to check if there are running obstruction, parts collision, uneven resistance or abnormal noise. If any of these exist, adjustment must be made accordingly before running.

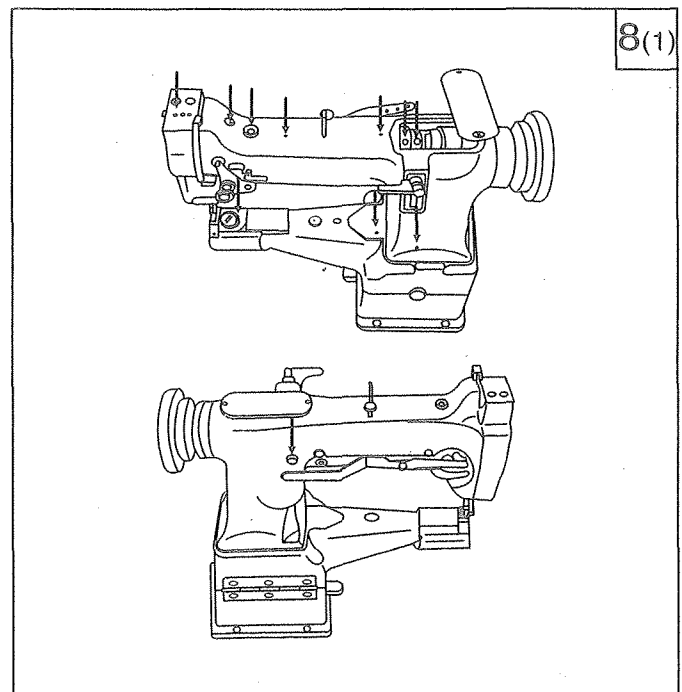

8(2)

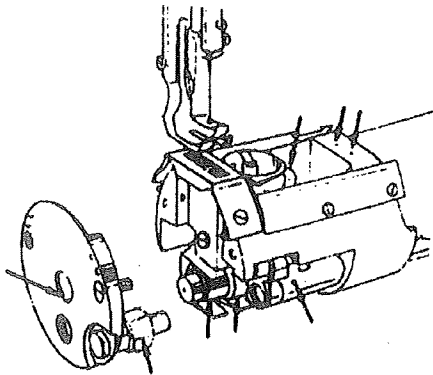
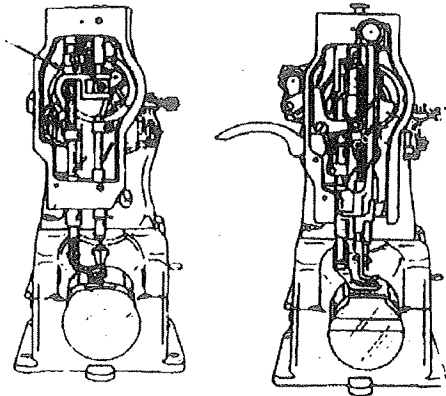

10. Lubrication (Fig. 8)

Before running, the machine must be oiled at the places by arrow as shown Fig.8. If the machine continues in operation, it should be oiled not less than twice per shift. Please use HA-8 sewing machine oil or TJ-7 machine oil.

11. Trial run

Trial running is required when new machine is put in to use or use again after operation for quite long time. Please lift the presser foot and run the machine at low speed of 1000-1500 s.p.m for 30 minutes, then increase the speed gradually.

9

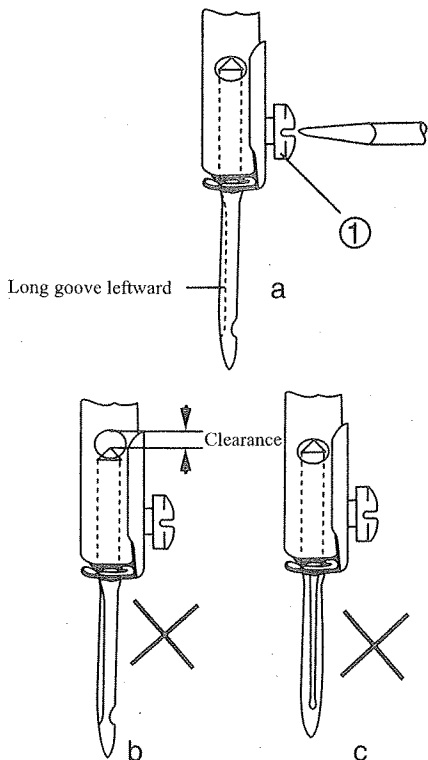

12. Installing the needle (Fig. 9)

Turn the balance wheel to lift the needle bar to its highest position, loosen the needle set screw 1, make the needle groove turn to the left side of the operator, fully insert the needle shank to the bottom of needle socket, then tighten the set screw 1.

Note: Fig.9b, insufficient insertion.

Fig.9c, wrong direction of groove.

13. Coordination among the needle, the thread and the material (Fig. 10)

The thread should be left-handed. Holding the thread (shown as Fig 10), twist it upward by right hand, if it changes into twice, it's right-handed, contrary, it's left-handed.

Needle number is DPx17,18# ~ 23#. The needle size should depend on the materials to be sewn. If the thin needle is used for sewing heavy material, the needle will be broken easily, and also will cause skip and thread broken. On the contrary, the material will be destroyed for the big needle hole. So please select proper needle according to the material.

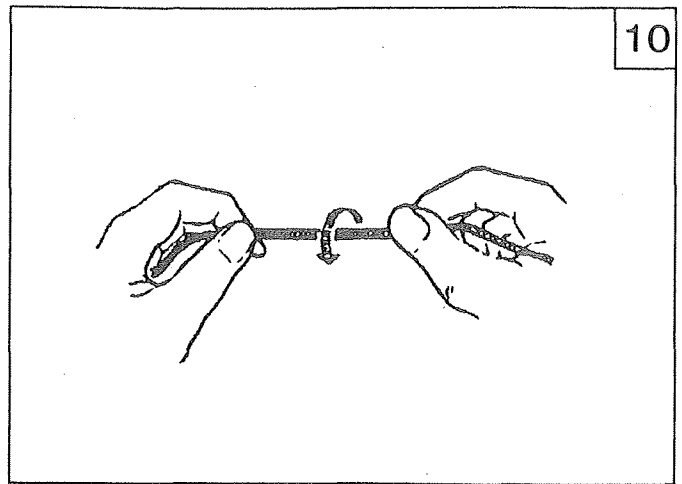

14. Threading the needle thread (Fig.11)

Turn the balance wheel to lift the thread take-up lever to the highest position.

The order as Fig .11: Thread pass-by pin A-Three-eye thread guide B - Thread tension C - Thread controller plate D-thread take-up spring E-Upper thread guide F-Thread take-up lever - Upper thread guide F- Middle thread guide H-Lower thread guide I-Needle bar thread guide J-Needle K.

When drawing the bobbin thread, hold the tip of the needle thread by hand, turn the balance wheel to lower the needle bar, then lift it to its highest position. Pull the needle thread and the bobbin thread is drawn up. Put the tips of the needle thread and bobbin thread toward front under the presser foot.

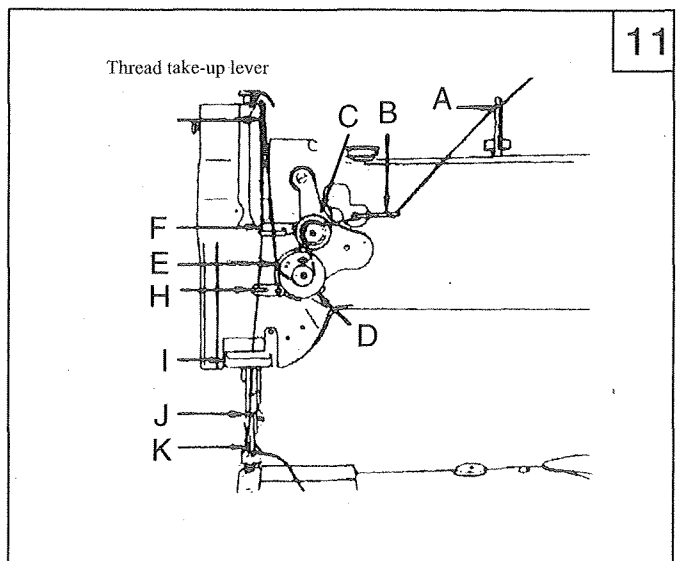

15. Adjusting the tension of bobbin thread and needle thread (Fig. 12)

The tension of the needle thread and bobbin thread should be suitable. The stitch form shown as (1) is the best. The abnormal stitch forms shown as (2),(3) will occur when the tension is tightened or loosened.

(1) Adjusting the tension of bobbin thread.

The tension of bobbin thread should be adjusted according to the material.

- ① Turn the balance wheel by hand to lift the thread take-up lever up to its highest position.
- ② Take down the sliding plate, the adjusting screw (A) is shown as 1.
- ③ Turn the adjusting screw (A) clockwise with the screw-knife to increase the tension.
- ④ Turn the adjusting screw (A) counter-clock wise to decrease the tension.

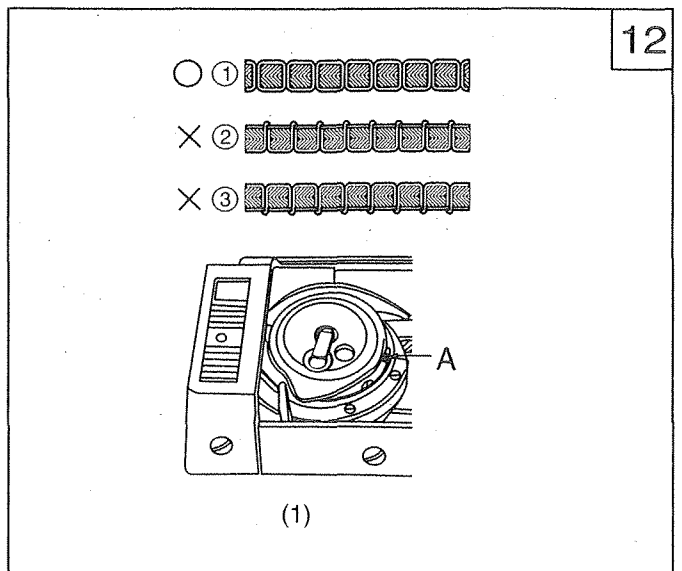

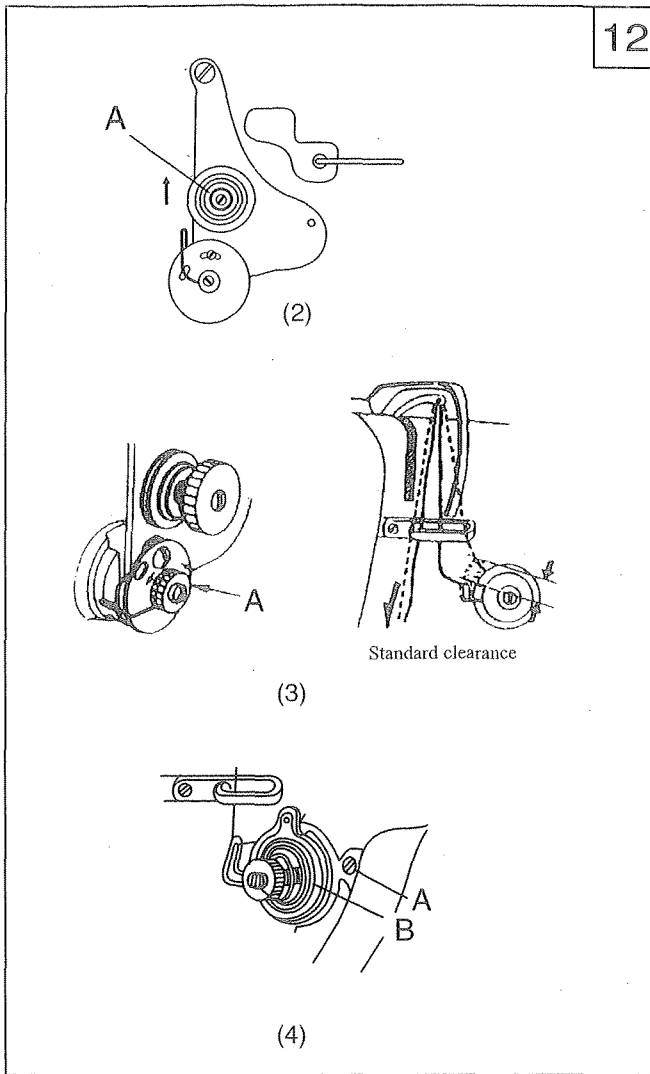

(2) Adjusting the tension of needle thread

① Adjust the pressure on the thread tension disc Adjust the pressure on thread tension disc to change the tension of needle thread. As Fig.(2), turn the nut(a)clockwise to increase the pressure, contrary, to decrease the pressure.

② Adjust the tension of thread take-up spring

- Thin material 20g
- Common material 25g
- Heavy material 30g

The method of adjusting:

loosen the nut A, turn the thread take-up spring shaft counter clockwise to increase the tension. Turn it clockwise to decrease the tension.

③ The swing range of thread take-up spring

The thread take-up spring need to be able to swing when the thread take-up lever is at its highest position.

The normal swing range of the thread take-up spring should be:

- Thin material over 8mm
- Common material about 8mm
- Heavy material less 8mm

The method of adjusting swing range

- ① loosen the presser foot lever;
- ② loosen the screw A;
- ③ Turn the thread take-up spring position disc B counter clockwise to increase the swing range, contrary, the swing range decrease.
- ④ Tighten the screw A.

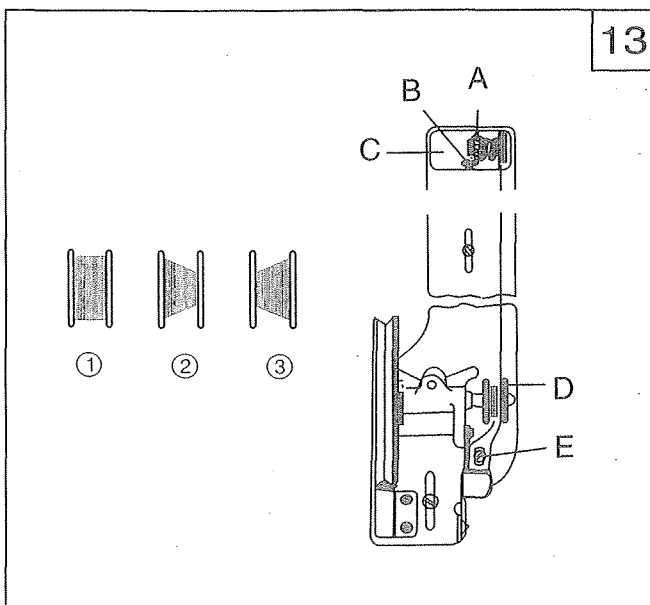

16. Winding the bobbin thread and adjustment (Fig. 13)

The bobbin thread should be neat and tight. If the thread is weak, please enlarge the pressure of the big thread tension disc A. If the thread is not neat, please move the bracket to adjust it. Firstly, loosen the screw B, if the thread is wound to one side as Fig.(2); please move the bracket rightward; if it is as Fig.(3), please move the bracket leftward. Move the bracket until the thread is wound neatly as Fig.(1), then tighten the screw.

Note: Nylon or polyester thread should be wound with light tension in particular, otherwise the bobbin D might be broken or deformed. Don't overfill the bobbin thread, because it makes thread loosen down from the bobbin. The optimum capacity of bobbin thread is fill about 80% of bobbin outside diameter, and this can be adjusted by screw(E).

17. Stitch length and forward and backward feeding (Fig. 14)

Turn the stitch length regulating nut to adjust the stitch length. When the graduation on the stitch Length regulating position block is aligned with the figure on the stitch length graduated plate, the figure is the stitch length. Press the reverse feed lever, the feeding is reverse. Release the lever, the machine recovers normal feeding again.

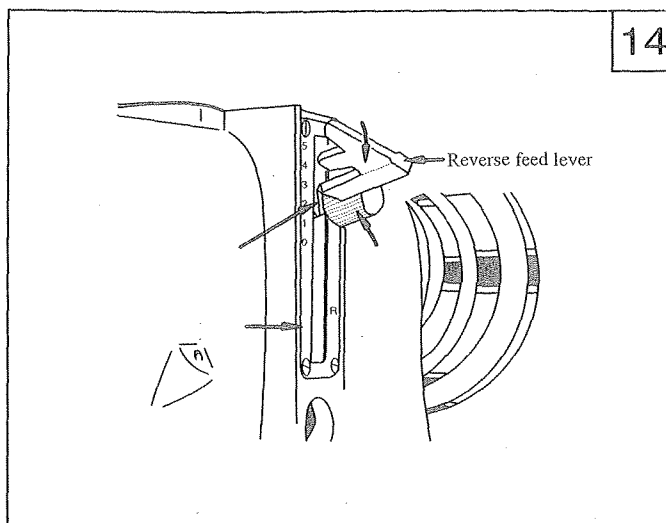

18. Adjusting presser foot pressure (Fig. 15)

Adjust the presser foot pressure according to the material. Please increase the pressure, when you sew heavy material. Turn the regulating screw clockwise to increase the pressure, contrary, decrease the pressure.

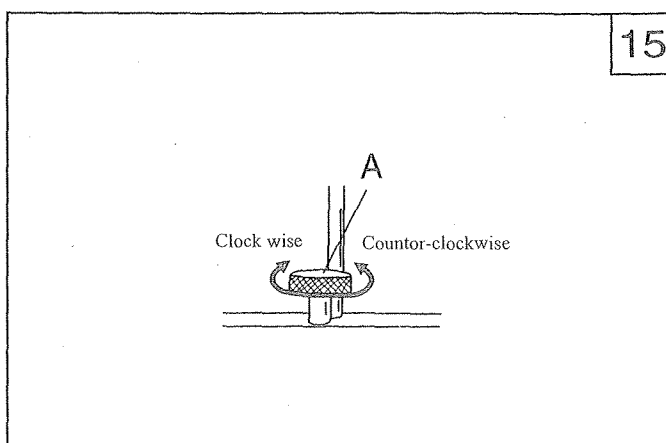

19. The function of the safety clutch and its using (Fig. 16)

The function of the safety clutch is preventing the hook and synchronous belt from destroys when the needle or thread is drawn into the hook for abnormal load during the operation.

When the eccentric pin arrow is aligned with the lower shaft center, the load on the safety clutch is small, increase the load when the arrow turns outside. Reset the safety clutch, the method is : Press the button B by left hand, and turn the balance wheel clockwise by right hand. When the stop plate stops the balance wheel, please turn the balance wheel to make the safety clutch return to the correct position, then release the button. And the synchronous belt should be installed again. At first, turn the balance wheel counter-clockwise when the thread take-up lever is on its highest position, and the red arrow in aligned with the arrow on the position plate,

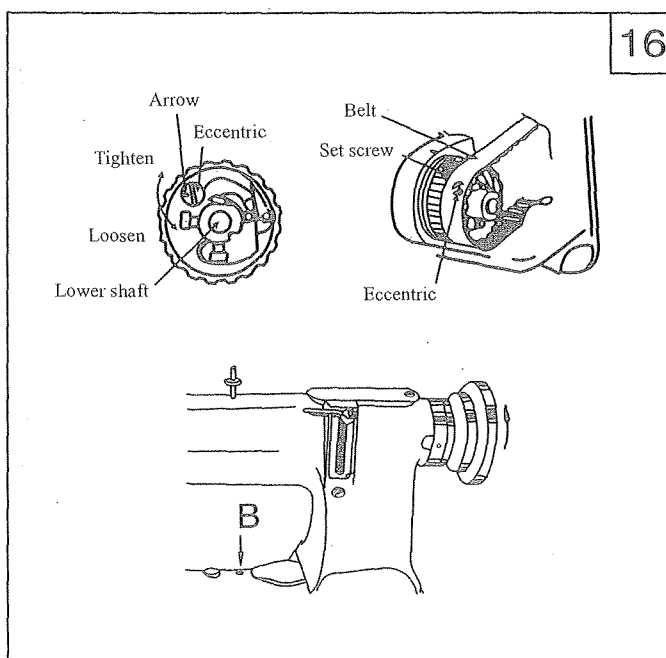

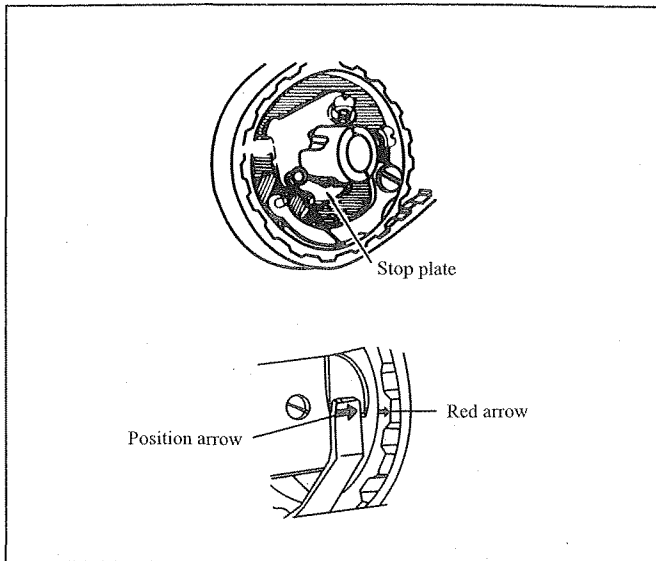

and then install the synchronous belt on the wheel.

20. Adjusting the presser foot lift volume (Fig. 17)

The method of adjusting the presser foot lift volume during the sewing is:

Loosen the nut A, adjust the center distance B between screw and shaft; Adjust the distance B short to increase the presser foot lift volume. Contrary, decrease the presser foot lift volume. Then tighten the screw after adjustment. Turn the upper shaft to check if there is any collision. Begin to use when every thing goes well.

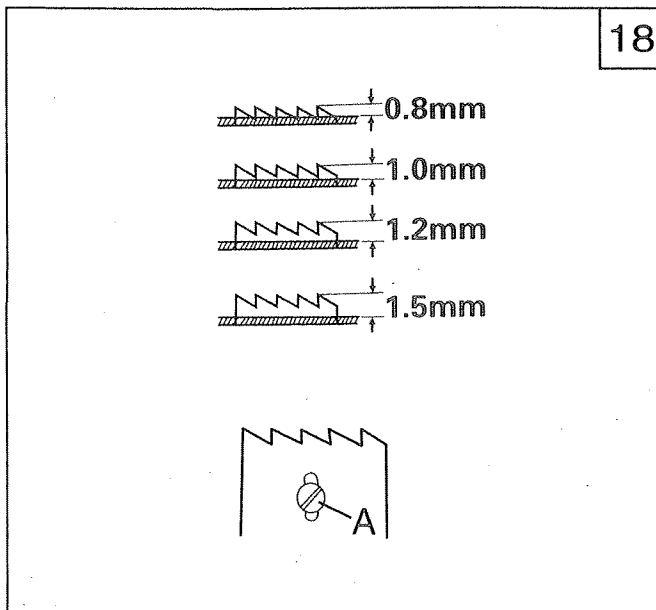
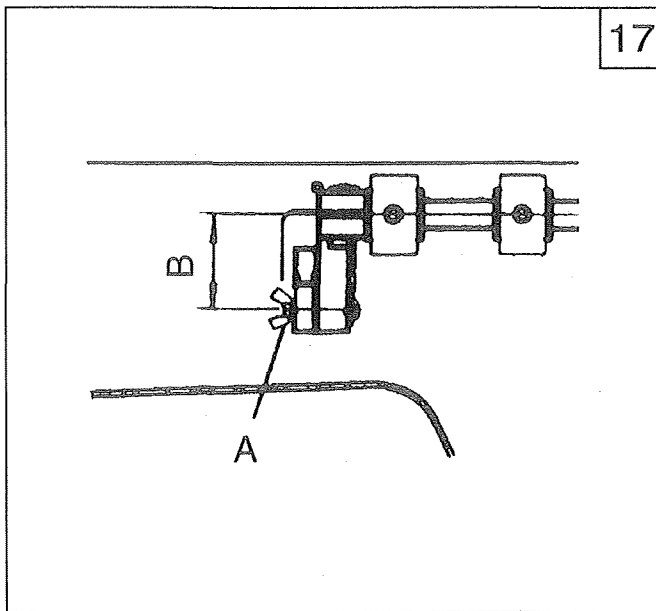

21. Adjusting the feed dog height position (Fig. 18)

Adjust the feed dog height according to the material. The feed dog height is 1.2mm for sewing leather or other heavy material; 0.8mm for sewing thin material; 1.5mm; for sewing extra heavy material. When adjusting the height, firstly loosen the screw A, move the feed dog to proper height, then tighten the screw.

22. Adjusting the timing of feed (Fig. 19)

① Standard position:

When the feed dog appears from the needle plate and begins to feed, the needle should move downward, and is near the needle plate and aligns with the hole on the plate. Please adjust the position of feed cam and rock shaft crank to adjust the timing of feed.

② Install the feed cam

At first, adjust the stitch length to zero, and open the upper cover, turn the balance wheel counter clockwise by right hand; divide two screw of the feed cam equally as the oil hold is bisector.

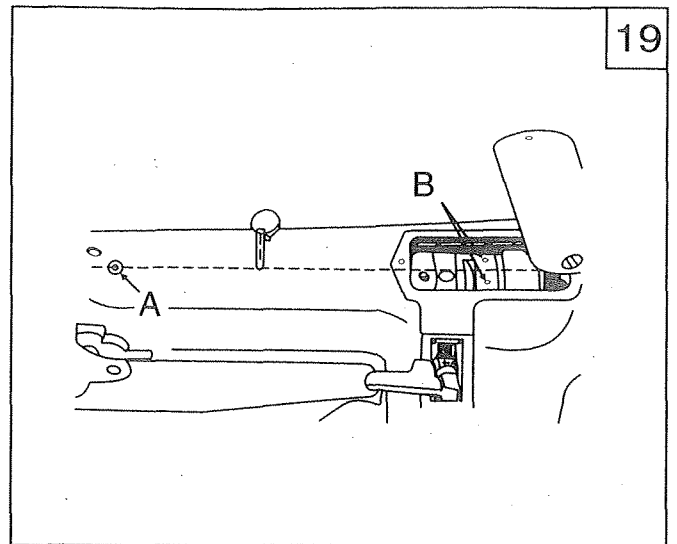

23. Adjusting the timing of needle and hook (Fig. 20)

The position between hook and needle could be set as following order. Lift the needle up to 2.5mm from its lowest position. The tip of hook should be straight to the needle center, there is about 1.6mm distance between the tip of hook and upside of needle hole. If the position is wrong, please loosen the screw A, move the needle bar up and down until its on proper position. Then tighten the screw. There is distance 0-0.05mm between the tip of hook and needle.

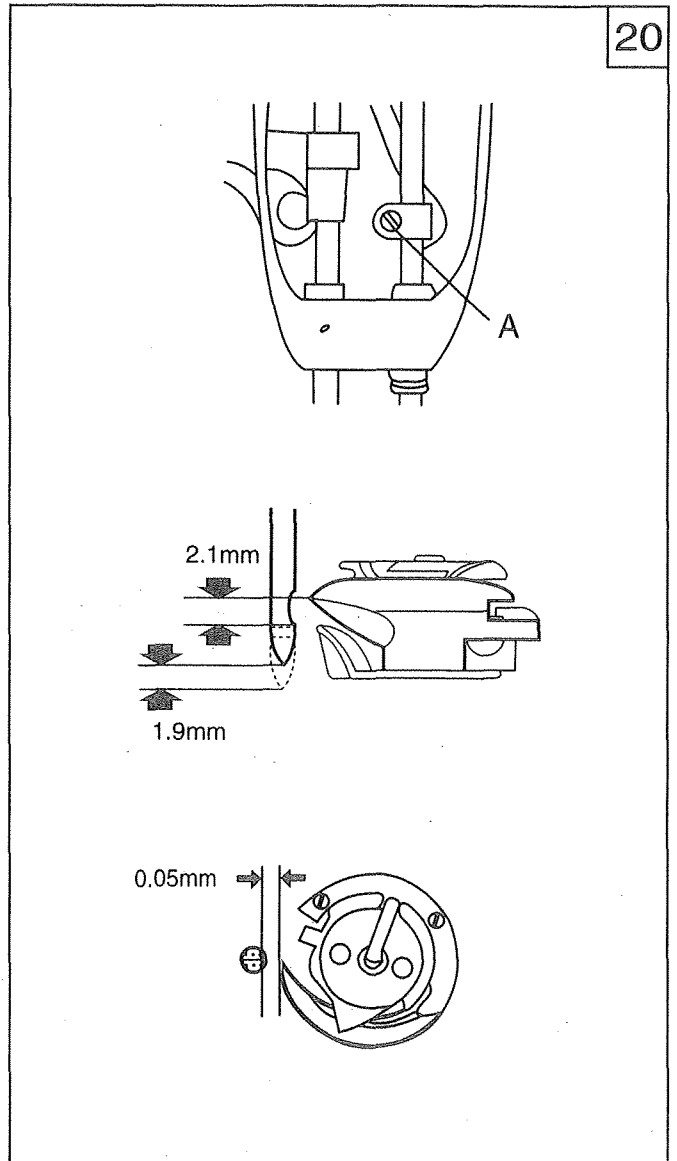

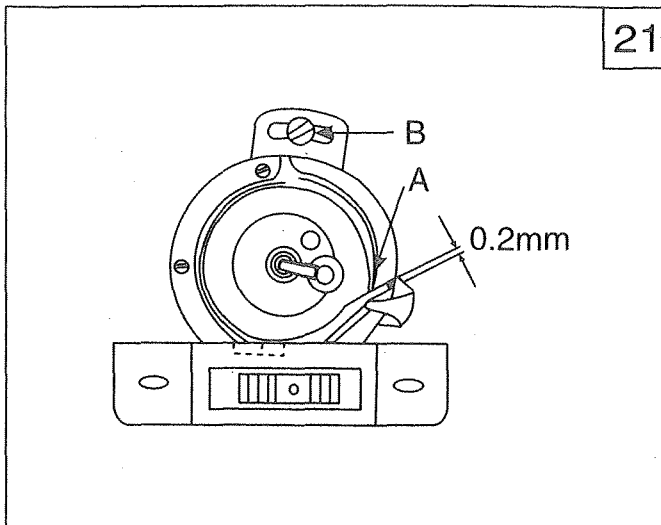

21

24. The relation between the hook and hook thread separate bracket(Fig.21)

- ① Take off the sliding plate.
- ② Turn the balance wheel until the largest clearance between the hook and the thread separate bracket appears.
- ③ Loosen the screw B to make the clearance become 0.2mm.(Please adjust according to the thread.)
- ④ Tighten the screw B.

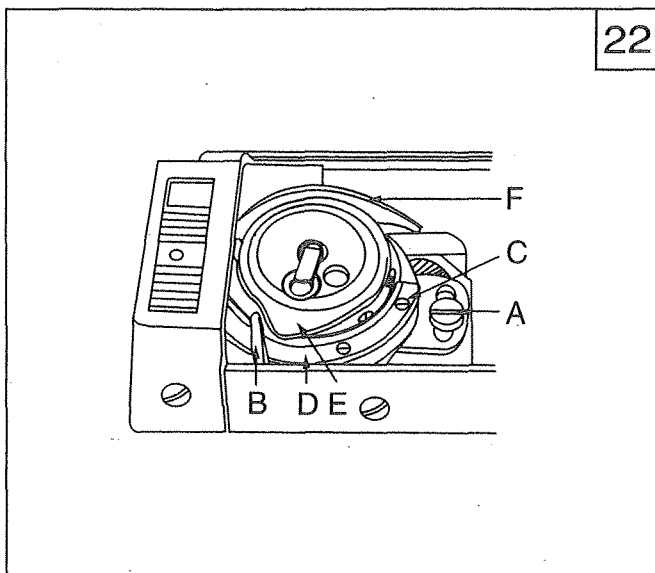

22

25. Installing the hook (Fig.22)

Replace the hook when the hook is damaged.

- ① Turn the balance wheel to make the needle bar move to its highest position, then take down the needle.
- ② Take down the sliding plate, needle plate, front and rear presser cover, bobbin.
- ③ Loosen the regulating screw A, take down the thread separate bracket B.
- ④ Loosen the screw C, take down the cover D.
- ⑤ Slowly move the hook head and take it out.

Install the hook:

Install the hook in the reverse order that the hook is taken down.

INDEX

	Pages
主要部分	1, 2
主体関係 Machine body	
针杆摆动部分	3, 4
针棒摇动関係 Needle bar rocking mechanism	
上轴挑线杆部分	5, 6
上轴・天秤関係 Arm shaft and thread take-up mechanism	
押脚部分	7, 8
押え関係 Presser foot mechanism	
送料机构	9, 10
上送り関係 Upper feed mechanism	
送料轴部分	11, 12
送り轴関係 Feed shaft mechanism	
下轴旋梭关系	13, 14
下轴・カマ関係 Lower shaft and rotary hook mechanism	
夹线部分	15, 16
糸调子関係 Thread tension	
倒缝关系	17, 18
バック関係 Feed reversing lever	
附属品部分	19, 20
付属品関係 Accessories	
另卖零件	21, 22
別売品 Parts available at extra charge	

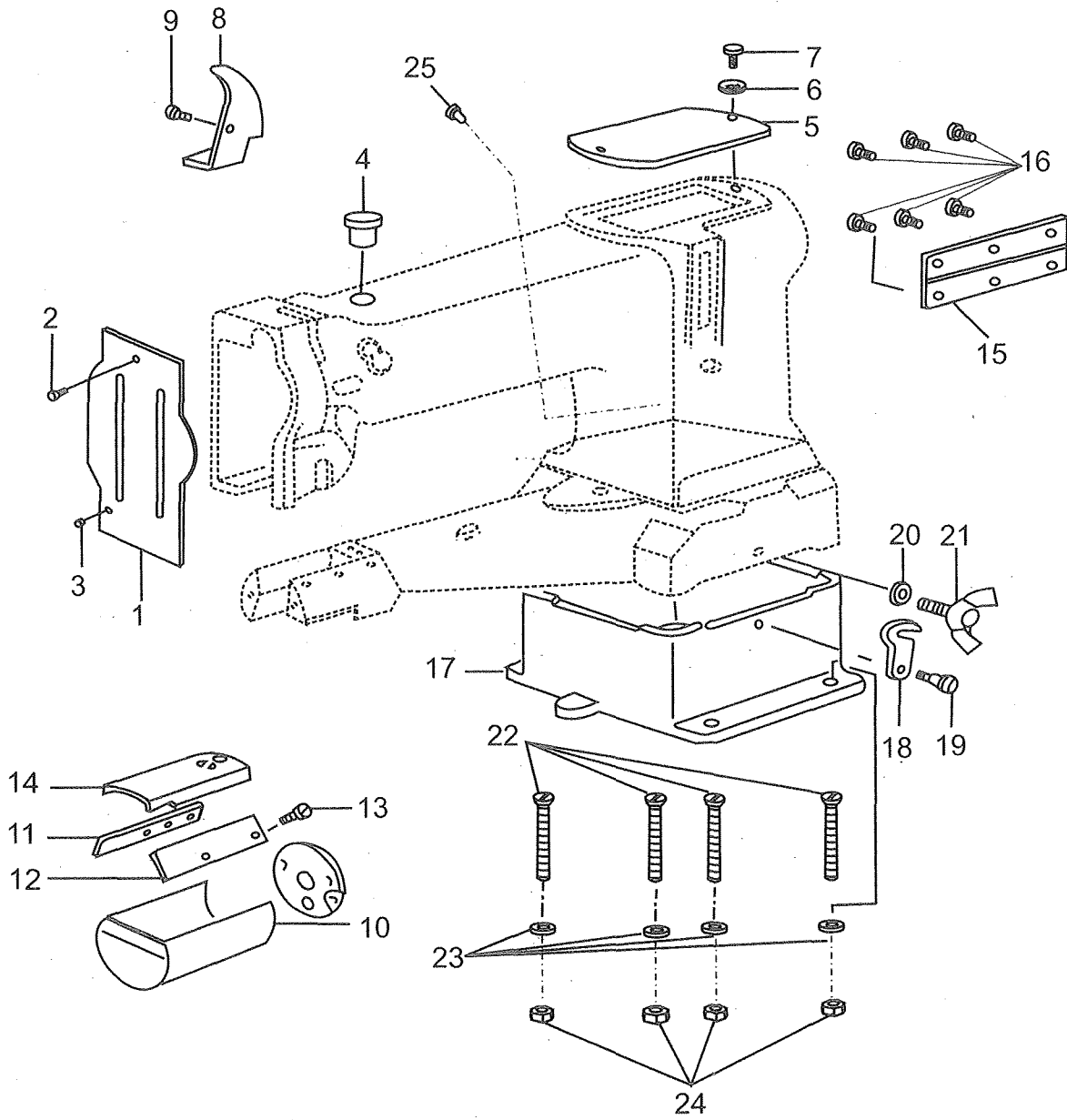

机体主要部分 / 主体関係 / Machine body

No.	零件号码 PARTS No.	数量 QTY	零件名称	品 名	PARTS NAME
1	10698	1	面板	面板	FACE PLATE
2	10699A	1	面板固定螺栓	面板止ねじ	THUMB SCREW 9/64"X40L=6.5
3	10700	1	面板销	油板ピン	PIN
4	10701-A	1	油栓	油栓(大)	PLUG
5	10702	1	上板	上板	ARM CAP
6	10703	1	上板垫圈	上板ワッシャー	WASHER
7	10704	1	螺丝	上板段ねじ	SCREW 3/16X28 L=6.5
8	10551	1	挑线杆防油板	天秤油受	OIL GUARD
9	10650A	1	防油板固定螺丝	天秤油受止ねじ	SCREW 9/64"X40L=6.0
10	13009	1	筒底部罩盖	シリンダーカバー	BED END COVER
11	13026	1	中推板左导轨	差し板案内(左)	GUIDE PLATE (REAR))
12	13025	1	中推板右导轨	差し板案内(右)	GUIDE PLATE(FRONT)
13	13027A	4	螺丝	止ねじ	SCREW 9/64"X40L=6.0
14	13024	1	中推板	差し板	BED SLIDE PLATE
15	13004	1	铰链	蝶番	BED HINGE
16	37100A	6	螺丝	止ねじ	SCREW M6X1L=10.0
17	13383	1	底座	ベース	MACHING BASE
18	13006	1	锁销	鍵	BED CLAMP
19	19403	1	锁销螺丝	カギ止ねじ	HINGE SCREW 1/4X28 L=5.4
20	13008	1	垫圈	ワッシャー	WASHER
21	13388-A	1	蝶形螺丝	蝶ボルト M6X1	SCREW M6X1L=20.0
22	13096A	4	平头螺栓	皿小ねじ 5/16X18L=75	SCREW M8 L=75
23	13096-W	4	垫圈	ワッシャー	WASHER
24	13096-NA	4	螺母	ナット	NUT M8
25	30046	1	固定地线用螺丝	アース線止ねじ	EARTH WIRE SCREW M4X0.7L=4.0

针杆摆动部分 / 针棒摇动關係 / Needle bar rocking mechanism

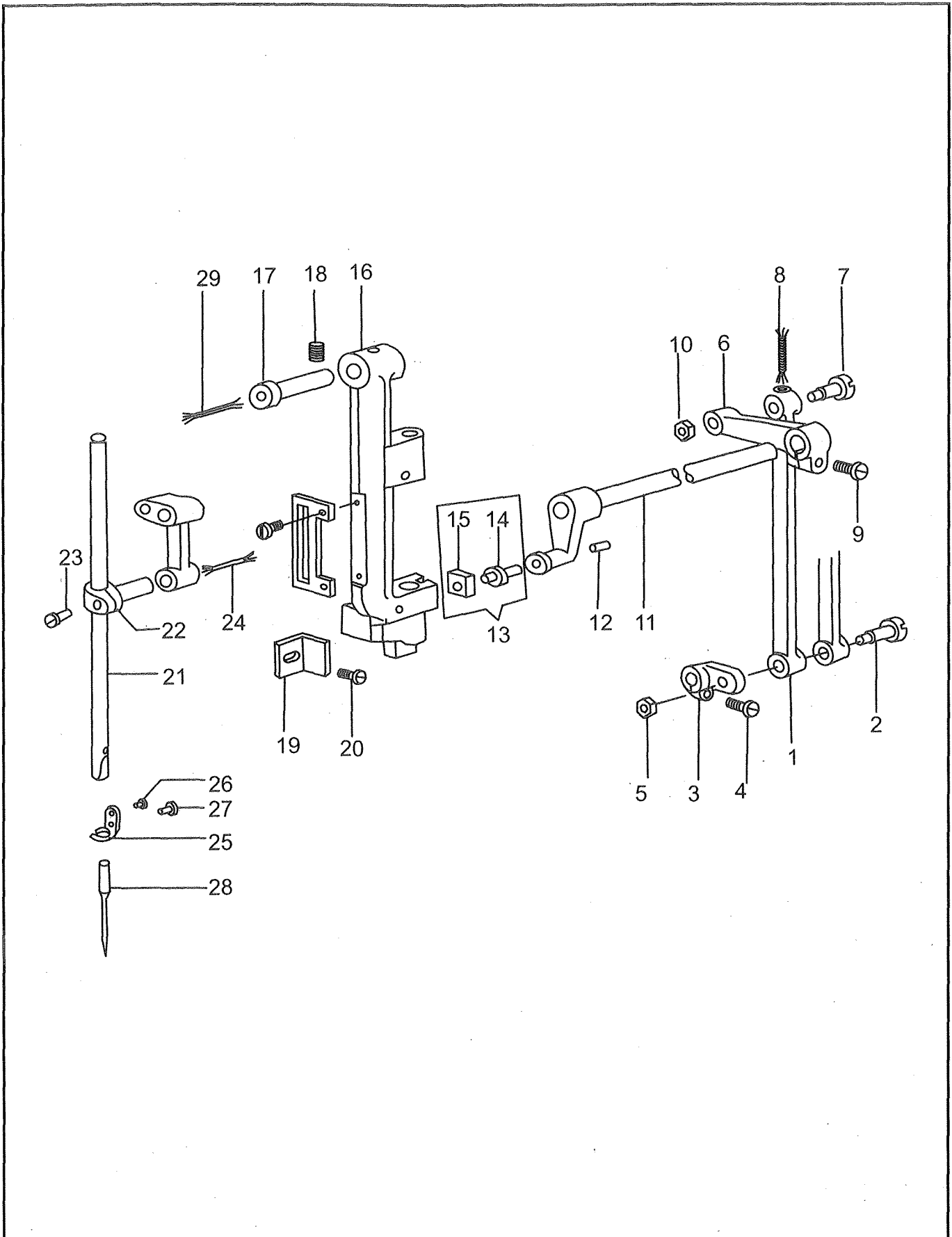

针杆摆动部分 / 针棒摇动関係 / Needle bar rocking mechanism

No.	零件号码 PARTS No.	数量 QTY	零件名称	品名	PARTS NAME
1	13071	1	联结连杆	連結ロッド	ROCK SHAFT CRANK CONNECTION
2	13396	1	连杆固定用螺丝	大段ネジ	HINGE SCREW
3	13395	1	送布杆曲柄	送り竿ダルマ	FEED ROCK BELL CRANK
4	13078A	1	螺丝	送り竿だるま締ねじ	PINCH SCREW 7/32X32L=13
5	13397	1	螺母	大段ねじナット	NUT M8X1.25
6	13364	1	曲柄	連結	FEED ROCK SHAFT CRANK
7	13363	1	螺丝	小段ねじ	HINGE SCREW
8	10728	1	连杆油芯	連結ロッド油芯	OIL WICK
9	19408	1	螺栓	連結締ねじ	PINCH SCREW 1/4X28L=17.5
10	16706	1	螺母	小段ねじナット	NUT 1/4X28
11	10578	1	上送布杆	上送り竿	NEEDLE BAR ROCK FRAME ROCK SHAFT
12	10581	1	螺丝	止ねじ	SET SCREW 7/32X32 L=7.0
13	11876C	1	上送布杆滑块组件	上送竿角玉組	SLIDE BLOCK COMPLETE
14	11876	1	上送布杆锁销	上送り竿ピンねじ	SLIDE BLOCK STUD
15	11877	1	上送布杆滑块	上送竿角玉	SLIDE BLOCK
16	15110-A	1	针杆架	針棒土台	NEEDLE BAR ROCK FRAME
17	11875	1	针杆架销	針棒土台ピン	HINGE STUD
18	10525A	1	针杆架锁销	針棒土台ピン止ねじ	SET SCREW 17/64"X32L=9.0
19	10560	1	角板	イケール	NEEDLE BAR ROCK FRAME POSITION BRACKET
20	10561A	1	固定角板用螺丝	イケール止ねじ	SCREW 11/64"X40L=6.5
21	19413	1	针杆	針棒	NEEDLE BAR
22	19426	1	针杆夹头	針棒抱き	NEEDLE BAR CONNECTING STUD
23	13365	1	螺丝	針棒抱き締ねじ	PINCH SCREW M4X0.7L=9.0
24	10726	1	油芯	針棒抱き油芯	OIL WICK
25	10533	1	针杆线勾	針棒糸掛	NEEDLE BAR THREAD GUIDE
26	6035	1	螺丝	針棒糸掛け止ねじ	SCREW 3/32X56 L=2.7
27	B140553	1	固定缝针用螺丝	針止ねじ	SET SCREW 1/8X40L=4.5
28	No122	1	缝针	針 DPX17 #22	NEEDLE DP X 17 #22
29	10726	1	针杆架油芯	針棒土台ピン油芯	OIL WICK

上轴挑线杆部分 / 上轴・天秤關係 / Arm shaft and thread take-up mechanism

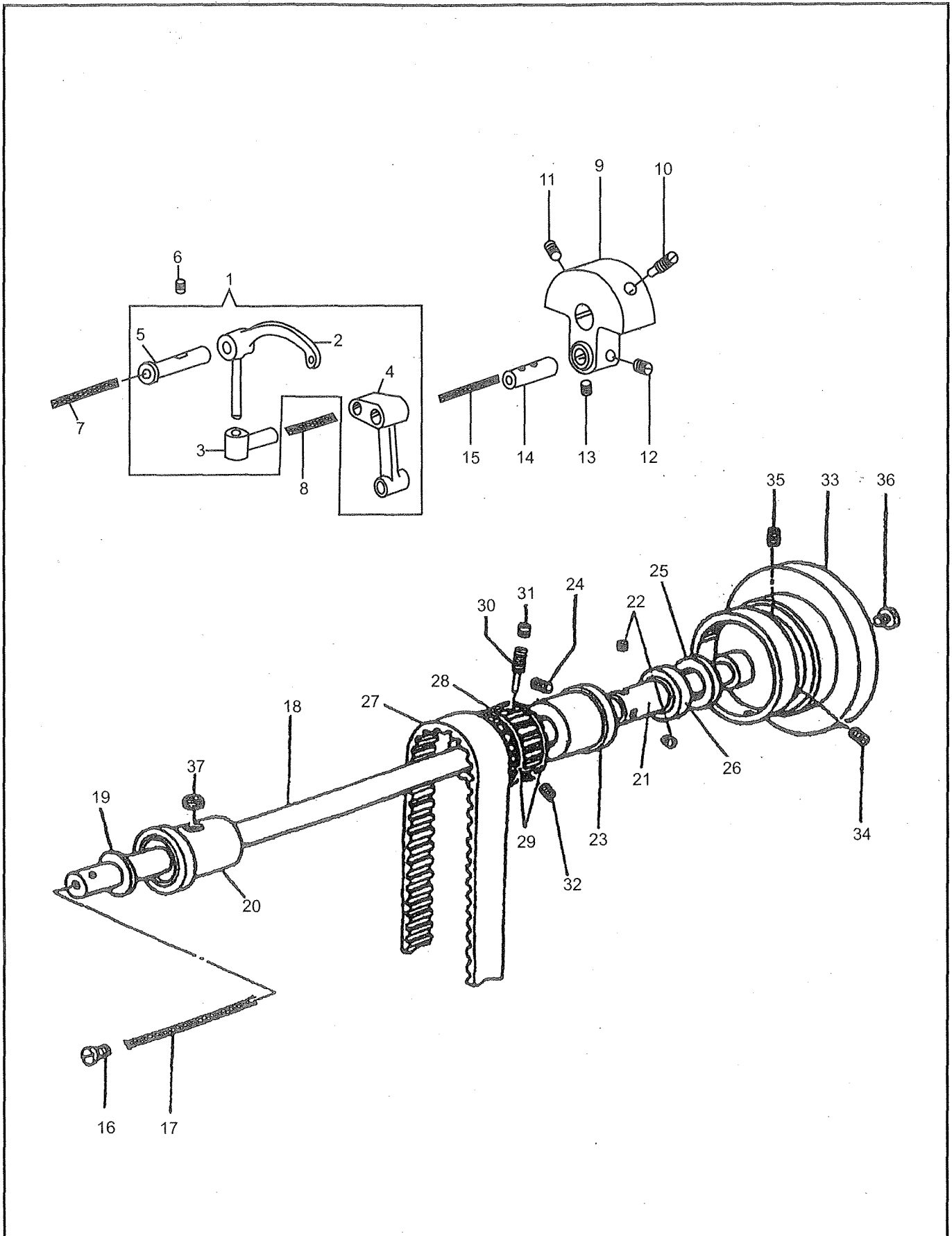

上轴挑线杆部分 / 上轴・天秤関係 / Arm shaft and thread take-up mechanism

No.	零件号码 PARTS No.	数量 QTY	零件名称	品名	PARTS NAME
1	10526C	1	挑线杆组件	天秤 (組)	THREAD TAKE-UP LEVER COMPLETE
2	10526	1	挑线杆	天秤	THREAD TAKE-UP LEVER
3	10529	1	挑线杆夹头	天秤抱き	THREAD TAKE-UPLEVER DRIVING STUD
4	10528	1	针杆曲柄	針棒クランク	NEEDLE BAR CONNECTING LINK
5	10527	1	挑线杆销	天秤ピン	THREAD TAKE-UP LEVER HINGE STUD
6	10525A	1	挑线杆锁销	天秤ピン止ねじ	SET SCREW 17/64"X32L=9.0
7	10726	1	油芯	天秤ピン油芯	OIL WICK
8	10728	1	油芯	天秤抱き油芯	OIL WICK
9	19414	1	曲柄凸轮	クランクモーションカム	NEEDLE BAR CRANK
10	19415	1	螺丝	クランクモーションカム位置決めねじ	POSITION SCREW 1/4X28 L=20.0
11	19416	1	螺丝	クランクモーションカム止ねじ	SET SCREW 1/4X28 L=14.0
12	19417	1	螺丝	針棒クランクピン止ねじ(長)	SCREW 1/4X28 L=6.5
13	19418	1	螺丝	針棒クランクピン止ねじ(短)	SCREW 1/4X28 L=4.5
14	10523	1	针杆曲柄销	針棒クランクピン	NEEDLE BAR CONNECTING LINK STUD
15	10726	1	油芯	針棒クランクピン油芯6X6	OIL WICK
16	10506A	1	上轴油栓螺丝	上軸油栓ねじ	OIL STOP SCREW 5/16"X28L=6.0
17	10724	1	上轴油芯	上軸油芯	OIL WICK
18	13557	1	上轴	上軸	ARM SHAFT
19	10563	1	上轴垫圈	上軸メタル(前)ワッシャー	WASHER
20	10562	1	上轴前轴套	上軸メタル(前)	ARM SHAFT BUSHING (FRONT)
21	13361	1	上轴轴承隔圈	上軸ベアリングカラー	BALL BEARING ADAPTER SLEEVE
22	23637	2	螺丝	上軸ベアリングカラー止ねじ	SET SCREW 1/4X28 L=7.5
23	13074	1	轴承盒	上軸ベアリングケース	BALL BEARING ADAPTER
24	10571A	1	轴承盒固定用螺丝	上軸ベアリングケース止ねじ	SCREW 17/64"X32L=20.0
25	10568	1	无槽轴承圈	溝なしリング	BALL BEARING RETAINING RING
26	10567	1	上轴轴承	上軸ベアリング	ARM SHAFT BALL BEARING
27	10621	1	同步皮带	タイミングベルト	ARM SHAFT CONNECTING BELT
28	10569	1	皮带上轮	上ベルトプーリー	BELT PULLEY (UPPER)
29	10574	2	皮带上轮环	上ベルトプーリーリング	BELT PULLEY SPRING FLANGE
30	10570A	1	定位螺丝	位置決めねじ	POSITION SCREW 1/4X28L=18.0
31	10524-GA	1	定位螺丝	位置決めねじ止ねじ	POSITION SCREW SET SCREW 1/4X28L=6.0
32	10571-GA	1	螺丝	止ねじ	SET SCREW 1/4"X28L=20.0
33	18470	1	上轮	プーリー	MACHINE PULLEY
34	10576	1	定位螺丝	プーリー位置決めねじ	POSITION SCREW 15/64X28 L=21.0
35	10579	1	定位螺丝	プーリー止ねじ	SET SCREW 15/64X28 L=20.0
36	10577A	1	定位螺丝	プーリー押しねじ	PULLEY ADJUSTING SCREW 11/32"X28L=11.0
37	10725	2	轴套油毡	上軸メタル(前)フェルト	OIL FELT

押脚部分 / 押え関係 / Presser foot mechanism

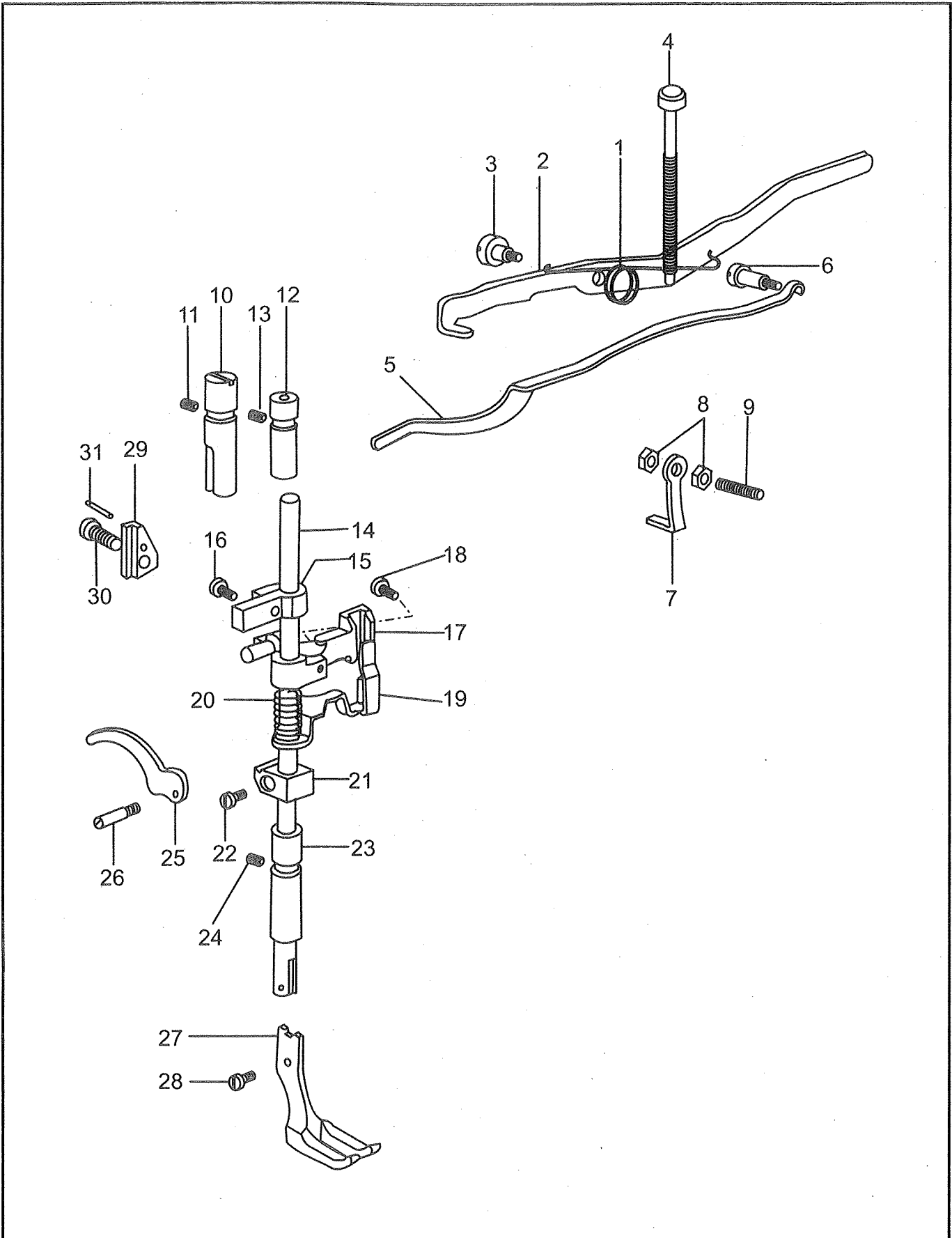

押脚部分 / 押え関係 / Presser foot mechanism

No.	零件号码 PARTS No.	数量 QTY	零件名称	品名	PARTS NAME
1	13056-A	1	抬押板	弓	FOOT LIFTING LEVER
2	13059	1	抬押板弹簧	弓ばね	FOOT LIFTING LEVER SPRING
3	10712A	1	螺丝	弓止ねじ	HINGE SCREW 1/4"X28L=6.9
4	10707A	1	调节螺栓	大板ばね調節ねじ	REGULATING SCREW 17/64"X32L=80.0
5	10705	1	压紧杆弹簧板	押え棒大板ばね	PRESSER BAR SPRING (FLAT)
6	10706A	1	弹簧板螺丝	大板ばね受ねじ	SUPPORT SCREW 1/4"X28L=11.0
7	13057	1	板簧架	弓受	LIFTING LEVER STOP
8	13084A	2	板簧螺母	弓受ナット	NUT 15/64"X28
9	13058A	1	板簧螺丝	弓受ねじ	SCREW 15/64"X28L=32.0
10	10543	1	导向杆	案内棒	PRESSER BAR POSITION GUIDE
11	10761A	1	螺丝	止ねじ	SET SCREW 17/64"X32L=11.0
12	10538	1	压紧杆轴套(上)	押え棒メタル(上)	PRESSER BAR BUSHING (UPPER)
13	10761A	1	螺丝	止ねじ	SET SCREW 17/64"X32L=11.0
14	10540	1	压紧杆	押え棒	PRESSER BAR
15	10541	1	压紧杆导向	押え棒案内	PRESSER BAR POSITION GUIDE BRACKET
16	10662A	1	螺丝	締めねじ	PINCH SCREW 9/64"X40L=7.0
17	18479	1	压紧杆夹头	押え棒抱き	PRESSER BAR LIFTING BRACKET
18	19518	1	螺丝	締めねじ	PINCH SCREW 11/64X40 L=14.0
19	10546-A	1	压紧杆夹头下板	押え棒抱き下板	TENSION RELEASE SLIDÉ
20	10547	1	压紧杆夹头弹簧	押え棒抱き下板ばね	TENSION RELEASE SLIDE SPRING
21	13360	1	压紧杆固定圈	押え棒抱きリング	PRESSER BAR SPRING (FLAT) BRACKET
22	13365	1	螺丝	押え棒抱きリング止ねじ	SET SCREW M4X0.7 L=9.0
23	10539-A	1	压紧杆轴套(下)	押え棒メタル(下)	PRESSER BAR BUSHING (LOWER)
24	10761A	1	螺丝	止ねじ	SET SCREW 17/64"X32L=11.0
25	10659	1	抬押柄	押え上げレバー	PRESSER BAR LIFTER
26	10660A	1	抬押柄锁销	レバーピンねじ	HINGE SCREW 11/64"X40L=7.5
27	10796-S	1	外押脚	外押え	LIFTING PRESSER FOOT
28	10664A	1	外踏脚固定用螺丝	外押え止	SCREW 9/64"X40L=5.0
29	10548-A	1	压紧杆夹头防振架	押え棒抱き振れ止台	LIFTING BRACKET GUIDE BLOCK
30	10519A	1	螺丝	止ねじ	SCREW 1/4X28L=17.5
31	15111	1	销	ピン	PIN

送料机构 / 上送り関係 / Upper feed mechanism

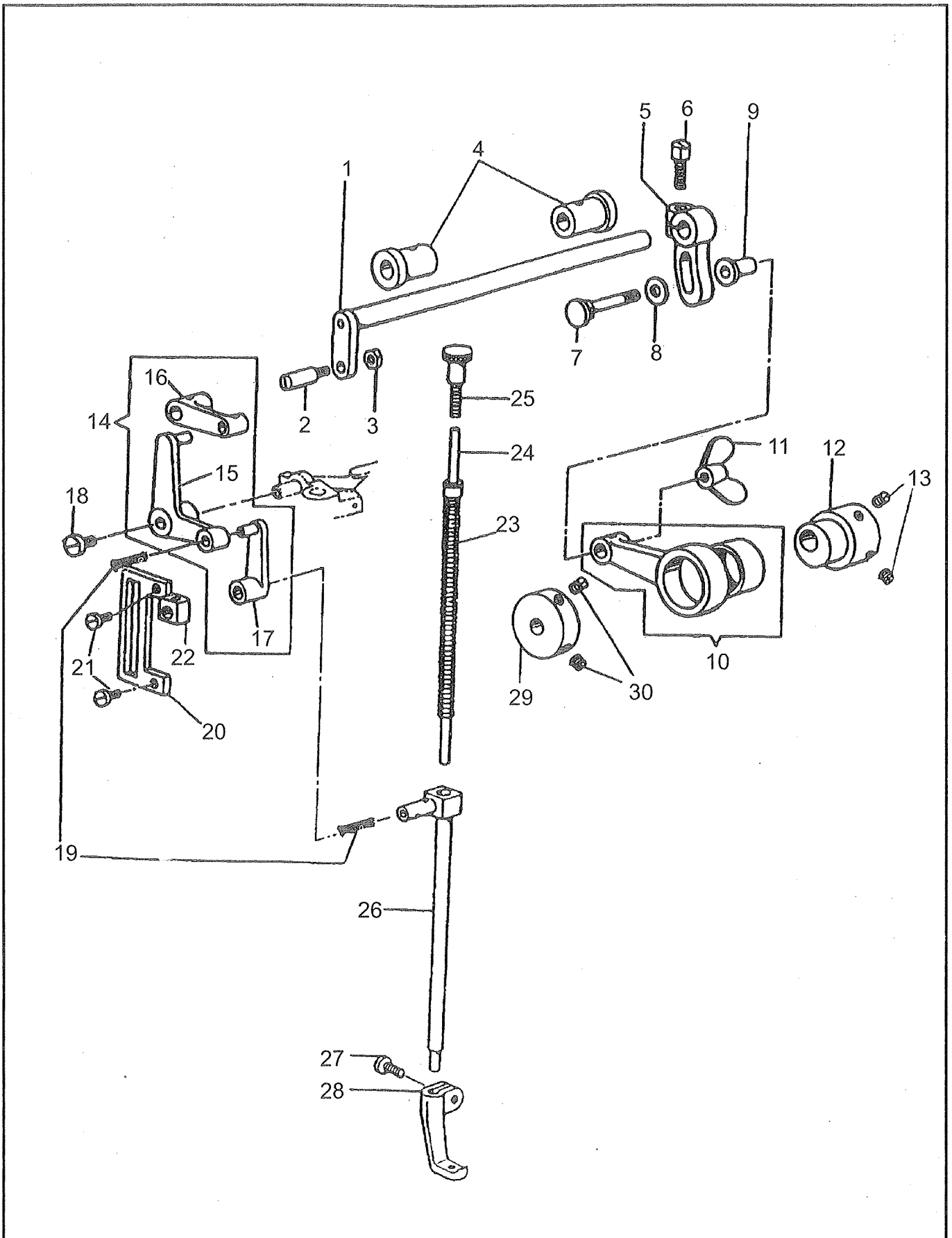

上送料机构 / 上送り関係 / Upper feed mechanism

No.	零件号码 PARTS No.	数量 QTY	零件名称	品名	PARTS NAME
1	19425	1	横轴	横軸	LIFTING ROCK SHAFT
2	19515	1	横轴锁销	横軸ピンねじ	SCREW STUD 1/4X28
3	19516	1	横轴锁销螺母	横軸ピンねじナット	NUT 1/4X28
4	10514	2	横轴轴套	横軸メタル	LIFTING ROCK SHAFT BUSHING
5	19419	1	上下凸轮联结夹头	上下カム連結ダルマ	LIFTING ECCENTRIC CONNECTING CRANK
6	19420	1	螺丝	締ねじ	PINCH SCREW 1/4X28 L=16.0
7	10775	1	上联结连杆螺丝	上連結ロッド段ねじ	HINGE SCREW 7/32X32
8	10703	1	垫圈	ワッシャー	WASHER
9	10774	1	上联结连杆套	上連結ロッドパイプ	LIFTING ECCENTRIC CONNECTION COLLAR
10	10772C	1	上联结连杆(组件)	上連結ロッド(組)	LIFTING ECCENTRIC CONNECTION COMPLETE
11	10776	1	上联结连杆蝶形螺母	上連結ロッド蝶ナット	NUT 7/32X32
12	19427	1	内押脚凸轮	中押え上下カム	LIFTING ECCENTRIC
13	19508	2	内押脚凸轮用螺丝	中押え上下カム止ねじ	SET SCREW 1/4X40 L=5.5
14	10558C	1	角形连杆组件	くの字セット	LIFTING BELL CRANK COMPLETE
15	10558	1	角形连杆	くの	LIFTING BELL CRANK
16	10557	1	角形连杆大联结	くの字連結(大)	LIFTING BELL CRANK LINK
17	10556	1	角形连杆小联结	くの字連結(小)	VIBRATING PRESSER BAR CONNECTING LINK
18	18480	1	角形连杆固定用螺丝	くの字止ねじ	LIFTING BELL CRANK CAP SCREW 11/64X40 L=8.0
19	10728	2	油芯	油芯	OIL WICK
20	15117	1	防震板	振れ止板	SLIDE BLOCK PLATE
21	8100	2	防震板固定用螺丝	振れ止板止ねじ	SCREW 9/64X40 L=6.5
22	15118	1	防震滑块	振れ止角玉	VIBRATING PRESSER BAR SLIDE BLOCK
23	10554	1	内押脚弹簧	中押えスプリング	VIBRATING PRESSER BAR EXTENSION SPRING
24	10553-A	1	内押脚弹簧杆	中押えスプリング棒	VIBRATING PRESSER BAR EXTENSION
25	10708	1	内押紧杆调节螺丝	中押え棒調節ねじ	SCREW 7/31X32 L=17.0
26	34713	1	内押紧杆	中押え棒	VIBRATING PRESSER BAR
27	17104A	1	螺丝	中押え締ねじ	PINCH SCREW 5/32"X40L=6.0
28	19411-S	1	内押脚	中押え	VIBRATING PRESSER FOOT
29	11879	1	内押脚上下凸轮隔圈	中押え上下カムカラー	LIFTING ECCENTRIC COLLAR
30	10573	2	隔圈固定用螺丝	中押え上下カムカラー止ねじ	SET SCREW 7/32X32 L=11.0

送料轴部分 / 送り軸関係 / Feed shaft mechanism

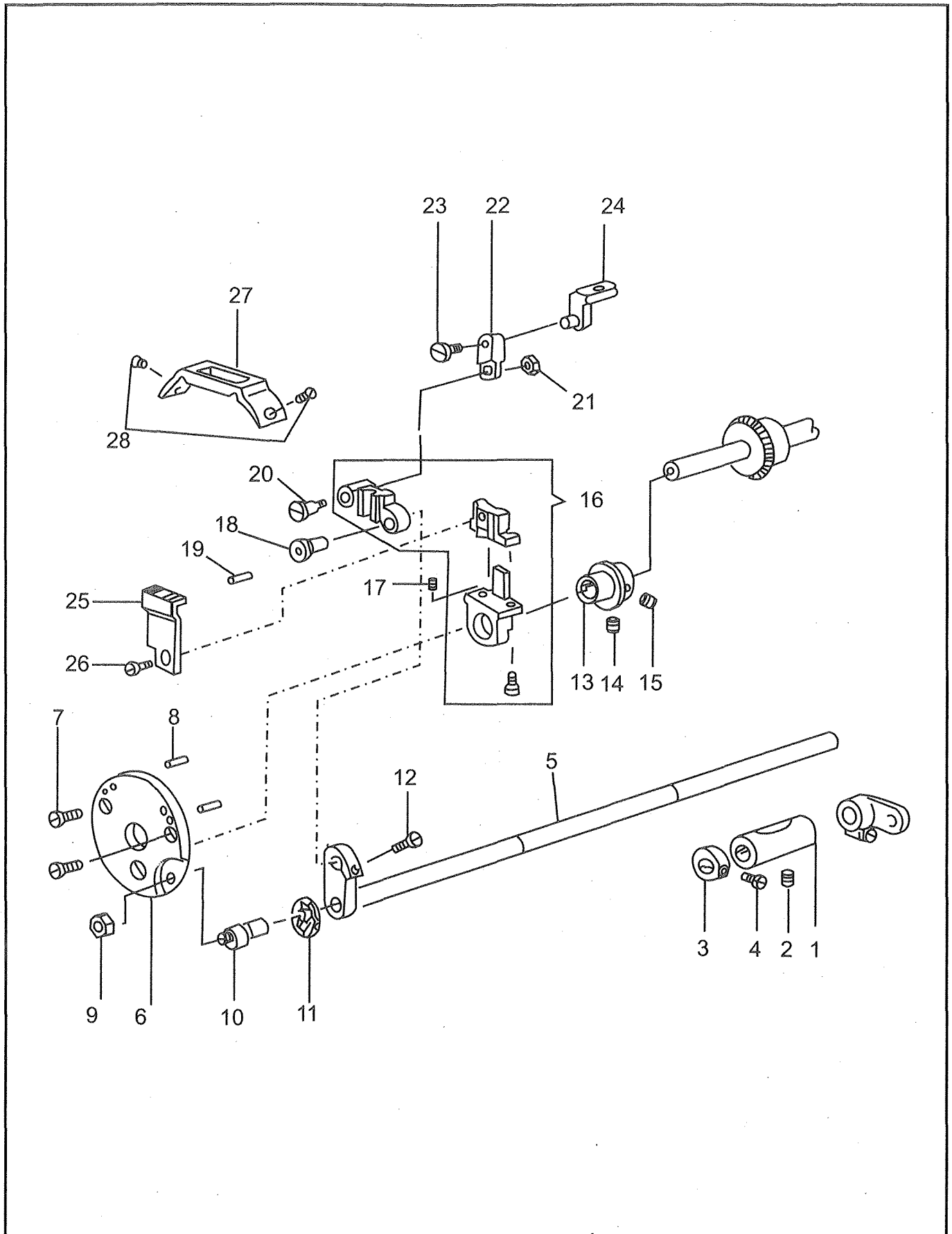

送料轴部分 / 送り轴関係 / Feed shaft mechanism

No.	零件号码 PARTS No.	数量 QTY	零件名称	品名	PARTS NAME
1	13029	1	送布杆轴套(后)	送り竿メタル(後)	FEED ROCK SHAFT BUSHING (REAR)
2	10766A	1	螺丝	止ねじ	SET SCREW 15/64"X28L=7.0
3	13049	1	送布杆隔圈	送り竿カラー	FEED ROCK SHAFT COLLAR
4	13033A	1	螺丝	止ねじ	SCREW M5X0.8L=2.5
5	13467	1	送布杆	送り竿	FEED ROCK SHAFT
6	13466	1	送料机构及轴固定用圆板	丸ぶた	BED CYLINDER CAP
7	13011A	2	螺丝	止ねじ	SCREW 3/16"X32L=10.0
8	13073	2	圆板销	丸ブタピン	BED CYLINDER CAP PIN
9	13076-01	1	送布杆固定用螺母	送り竿ピンねじナット	NUT 7/32X32
10	13468	1	送布杆固定用螺丝	送り竿ピンねじ	STUD SCREW 7/32X32
11	13080	1	送布杆固定用油毡	送り竿ピンネジフェルト	OILING FELT
12	10532A	1	螺丝	止ねじ	PINCH SCREW M4X0.7L=8.5
13	13340	1	凸轮	送り上下カム	FEED LIFTING CAM
14	13031A	1	定位螺丝	位置決めねじ	POSITION SCREW M5X0.8L=4.7
15	13085A	1	螺丝	止ねじ	SET SCREW M5X0.8L=4.3
16	13473C	1	送布架(4点)组件	送り台(4点)組	FEED BASE COMPLETE
17	13472A	1	螺丝	送り歯ストッパー止ねじ	SCREW M2.5X0.45 L=6.5
18	13475	1	送布架导向销	送り台案内ピン	HINGE PIN
19	0148-H	1	油毡	フェルト(丸棒3X5)	FELT
20	13477	1	送布联结螺丝	送り連結段ねじ	HINGE SCREW 11/64X40
21	10652	1	送布联结螺母	送り連結段ねじナット	NUT 11/64X40
22	13476	1	送布联结	送り連結	FEED CONNECTION
23	13479	1	螺丝	送り連結止ねじ	SCREW 9/64X40L=6.5
24	13478	1	送布联结架	送り連結台	FEED CONNECTION BASE
25	13020	1	送布牙	送り歯	FEED DOG
26	200181A	1	螺丝	送り歯止ねじ	SCREW 11/64"X40L=6.2
27	13022	1	针板	針板	THROAT PLATE
28	13023A	2	螺丝	止ねじ	SCREW 9/64"X40L=8.0

下轴旋梭关系 / 下轴・カマ関係 / Lower shaft and rotary hook mechanism

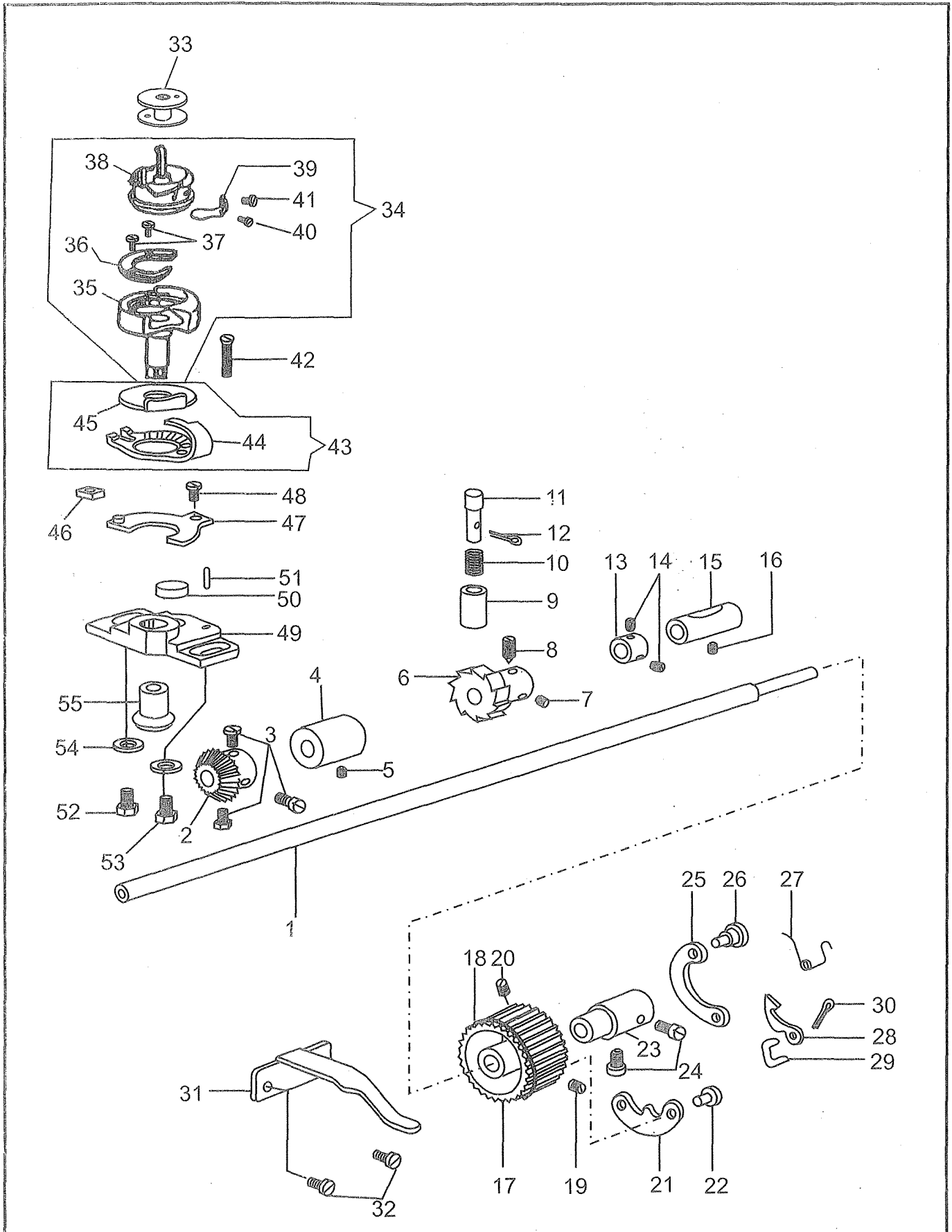

下轴旋梭关系 / 下轴・カム関係 / Lower shaft and rotary hook mechanism

No.	零件号码 PARTS No.	数量 QTY	零件名称	品名	PARTS NAME
1	13456	1	下轴	下軸	HOOK DRIVING SHAFT
2	13032	1	大伞齿轮	大ギヤー	HOOK DRIVING GEAR
3	13033	3	螺丝	大ギヤー止めねじ	SET SCREW 13/64X32 L=5.0
4	13028	1	下轴轴套(前)	下軸メタル(前)	HOOK DRIVING SHAFT BUSHING(FRONT)
5	10764A	1	固定轴套用螺丝	下軸メタル(前)止めねじ	SET SCREW 15/64"X28L=4.5
6	13362	1	棘轮	爪車	HOOK DRIVING SHAFT LOCK RATCHET
7	23634	1	定位螺丝	位置決めねじ	POSITION SCREW 1/4/28 L=6.0
8	23637	1	定位螺丝	止めねじ	SET SCREW 1/4X28L =7.5
9	13045	1	按钮架	押しボタン土台	LOCK STUD SOCKET
10	13047	1	按钮弹簧	押しボタンスプリング	LOCK STUD SPRING
11	13046	1	按钮	押しボタン	LOCK STUD
12	15076	1	开口销	割りピン	PIN
13	13049	1	下轴隔圈	下軸カラー	HOOK DRIVING SHAFT COLLAR
14	13050A	2	螺丝	下軸カラー止	SET SCREW M5X0.8L=4.5
15	13029	1	下轴轴套(后)	下軸メタル(後)	HOOK DRIVING SHAFT BUSHING (REAR)
16	10767A	1	轴套固定用螺丝	下軸メタル(後)止めねじ	SET SCREW 15/64"X28L=4.5
17	13424-01	1	下皮带轮	下ベルトプーリー	LOWER PULLEY
18	10574	1	皮带轮环	プーリーリング	PULLEY SPRING FLANGE
19	10581	1	螺丝	止めねじ(掛金ピン用)	SET SCREW 7/32X32 L=7.0(FOR LEVER HINGE STUD)
20	10581	1	螺丝	止めねじ(ヒンジピン用)	SET SCREW 7/32X L=7.0(FOR HINGE PIN)
21	10616	1	下轮挂勾	下ベルトプーリー掛金	SAFETY CLUTCH LOCKING LEVER
22	10613	1	挂勾销	下ベルトプーリー掛金ピン	LEVER HINGE STUD
23	10611	1	挂勾心棒	下ベルトプーリー芯棒	SAFETY CLUTCH COLLAR
24	10612	2	螺丝	止めねじ	SCREW 1/4X32 L=10.5
25	10615	1	下轮板簧	下ベルトプーリー板ばね	SAFETY CLUTCH LOCKING LEVER SPRING
26	10614	1	销	ヒンジピン	HINGE PIN
27	10619	1	下轮弹簧	下ベルトプーリースプリング	THROW-IN LATCH SPRING
28	10617	1	下轮小勾	下ベルトプーリー小爪	SAFETY CLUTCH RATCHET
29	10618	1	下轮小联结	下ベルトプーリー小連結	RATCHET CONNECTION LINK
30	10620	1	下轮开口销	下ベルトプーリー割りピン	THROW-IN LATCH PIN
31	13054	1	调节皮带轮用定位	タイミングプレート	BELT TIMING PLATE
32	10597	2	螺丝	止めねじ	SCREW 1/8X40 L=3.3
33	10656	1	梭心	ボビン	BOBBIN
34	13086C	1	旋梭(组件)	カム(組)	HOOK COMPLETE
35	13086-01	1	外旋梭	外カム	HOOK
36	16291-03	1	内旋梭压紧板	内カム押え	HOOK GIB
37	16407-04	2	压紧螺丝	内カム押え止めねじ	HOK GIB SCREW
38	10655-02	1	内旋梭	内カム	BOBBIN CASE
39	16291-07	1	调线弹簧	糸調子ばね	BOBBIN CASE TENSION SPRING
40	16291-08	1	弹簧固定用螺丝	糸調子ばね調子ねじ	TENSION REGULATING SCREW
41	16407-11	1	固定螺丝	糸調子ばね止めねじ	SCREW
42	13087A	1	旋梭固定螺栓	カム止	HOOK SET SCREW 9/64"X40L=21.0
43	13041C	1	分线勾旋梭板(组件)	オープナー・カム板(組)	OPENER& HOOK WASHER COMPLETE
44	13041	1	梭壳分线勾	ボビンケースオープナー	BOBBIN CASE OPENER
45	13042	1	旋梭板	カム板	HOOK WASHER
46	13040	1	滑板	小角駒	BOBBIN CASE LEVER ECCENTRIC BLOCK
47	13038	1	分线勾调节板	オープナー調節板	LEVER FULCRUM W/STUD
48	8040	1	螺丝	止めねじ	SCREW 9/64X40 L=8.0
49	13464	1	旋梭架	カム土台	HOOK SADDLE
50	13081	1	油毡	フェルト	OIL FELT
51	0148-A	1	油毡	フェルト(丸棒3X10)	OIL FELT
52	13717A	1	螺栓(长)	止めねじ(長)	SCREW M5X0.8L=16.5
53	13036A	1	螺栓(短)	止めねじ(短)	SCREW M5X0.8L=12.0
54	13037	2	垫圈	ワッシャー	WASHER
55	13034	1	小伞齿轮	小ギヤー	HOOK BEVEL GEAR

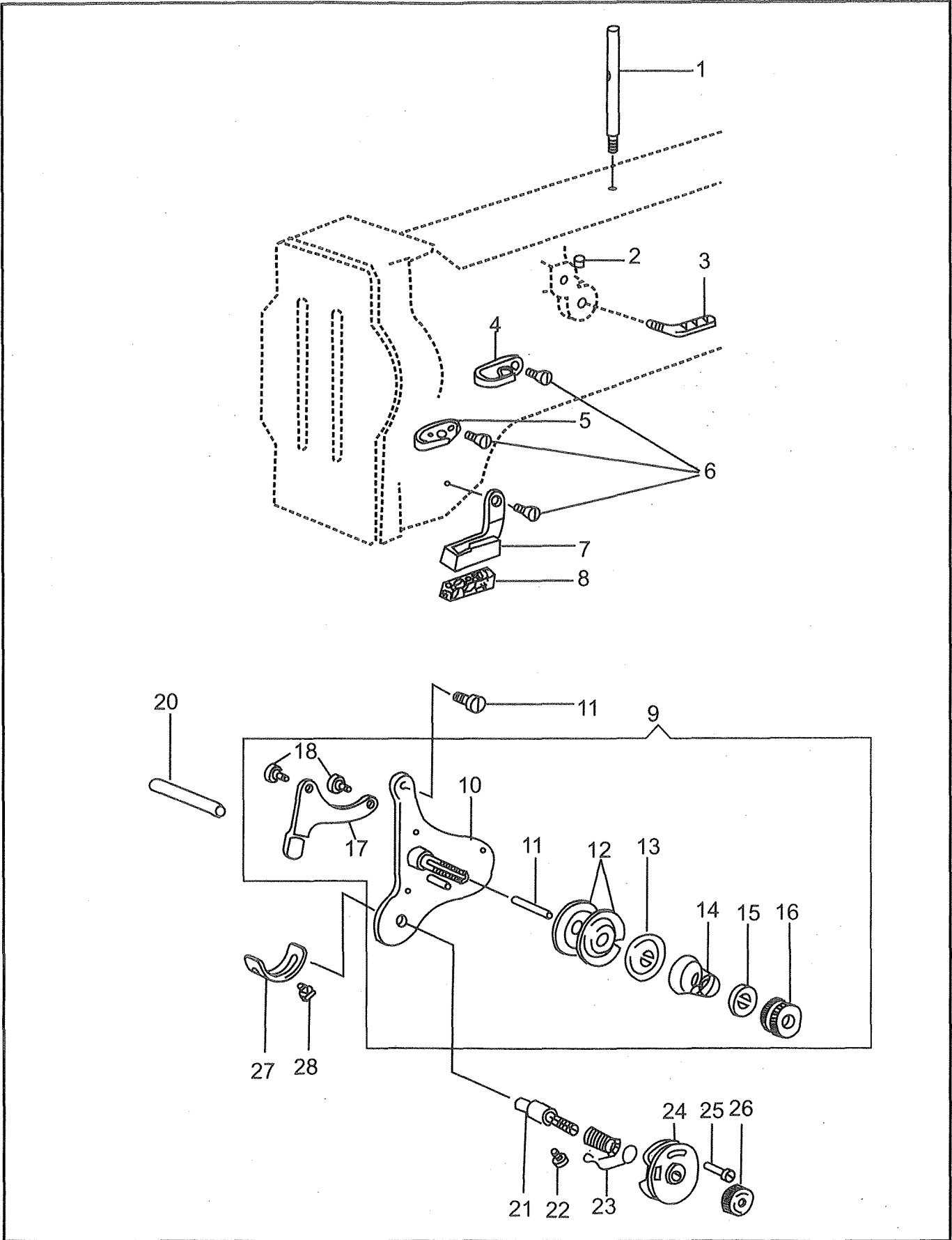

夹线部分 / 糸调子関係 / Thread tension

No.	零件号码 PARTS No.	数量 QTY	零件名称	品名	PARTS NAME
1	10709	1	过线丁	糸立棒	ARM SPOOL PIN
2	10681A	1	螺丝	止ねじ	SET SCREW 9/64"X40L=6.5
3	10680	1	三孔过线丁	三つ孔糸掛	THREAD RETAINER
4	10682	1	上线丁	面糸掛(上)	THREAD GUIDE (UPPER)
5	10683	1	中线丁	面糸掛(中)	THREAD GUIDE (MIDDLE)
6	10685A	3	螺丝	止ねじ	SCREW 9/64"X40L =6.5
7	10759-A	1	下线丁	面糸掛(下)	THREAD GUIDE (LOWER)
8	10760	1	油毡	フェルト	FELT
9	19421C-A	1	调线底板组件	調子板組	TENSION BRACKET COMPLETE
10	19421	1	调线底板	調子板	TENSION BRACKET
11	10793	1	松线销	糸ゆるめ段ピン	TENSION RELEASE PIN
12	19531	2	调线板	調子皿	TENSION DISC
13	19532	1	垫片	丸一皿	TENSION RELEASE WASHER
14	19533	1	调线弹簧	渦巻スプリング(Φ1.4)	TENSION SPRING(Φ1.4)
15	28206	1	垫片	ローレットストッパー	NUT WASHER
16	19513A	1	滚花螺母	ローレットナット	TENSION THUMB NUT 7/32X40
17	10678	1	松线板	糸ゆるめ板	TENSION RELEASE PLATE
18	19422	2	松线板销子	糸ゆるめ板段ピン	HINGE SCREW 9/64X40
19	18085	1	螺丝	止ねじ	SCREW 11/64X40 L=8.5
20	10720	1	松线板销子	糸ゆるめピン(長)	TENSION RELEASE LEVER ROD
21	19512	1	勾线弹簧杆	糸引スプリング棒	TENSION CONTROLLER STUD
22	10545	1	螺丝	止ねじ	SET SCREW 11/64X40 L=14
23	10689	1	勾线弹簧	糸引スプリング	THREAD TAKE-UP SPRING
24	10694	1	垫片	二重皿	THREAD CONTROLLER DISC
25	B118319	1	螺丝	止ねじ(短)	SCREW 3/32X56 L=6.0
26	19534	1	滚花螺母	ローレットナット	TENSION THUMB NUT
27	10690	1	弹簧架	スプリング受	TAKE-UP SPRING STOP
28	10650A	1	螺丝	止ねじ	SCREW 9/64X40

倒縫关系 / バック関係 / Feed reversing lever

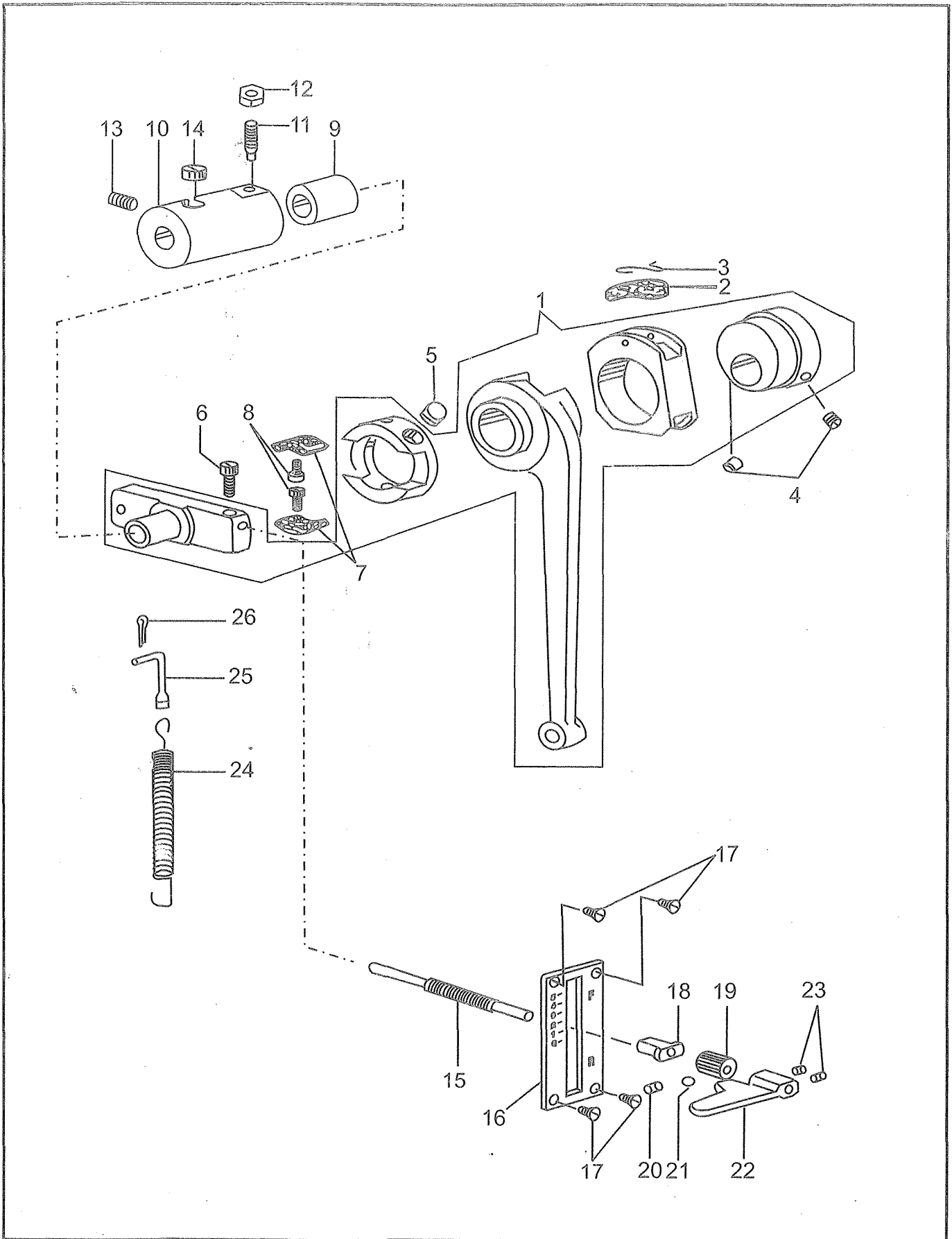

倒缝关系 / バック関係 / Feed reversing lever

No.	零件号码 PARTS No.	数量 QTY	零件名称	品名	PARTS NAME
1	13403C	1	送布连杆5点组件	送りロッド5点 (組)	FEED ROD (5 PARTS)COMPLETE
2	10722	1	油毡	フェルト	OIL FELT
3	10723	1	油毡押簧	フェルト押え	OIL FELT STOPPER
4	19508	2	螺丝	送りカム止ねじ	SET SCREW 1/4X40 L=5.5
5	11069	1	油毡	送りロッド案内フェルト	OIL FELT
6	27177	1	螺丝	止ねじ(大)	SCREW M5X0.8 L=16.0
7	13412	2	油毡	フェルト	OIL FELT
8	10597	2	螺丝	フェルト止ねじ	SCREW 1/8X40 L=3.3
9	13407	1	内轴套	割メタル	SUPPORTING BUSHING
10	13387	1	上轴中轴套	上軸メタル(中間)	ARM SHAFT BUSHING (MIDDLE)
11	19415	1	螺丝	止ねじ	SCREW 1/4X28 L=20.0
12	4113	1	螺母	止ナット	NUT 1/4X28
13	10571A	1	螺丝	止ねじ	SET SCREW 17/64"X32L=20.0
14	10725	1	油毡	フェルト	OIL FELT
15	13415	1	手柄插销螺丝	シバーピンねじ	FEED REGULATING LEVER
16	13418	1	送量调节板	送り調節板	STITCH LENGTH PLATE
17	7041A	4	螺丝	止ねじ	SCREW 1/8X40L=7.0
18	13417	1	送量调节套	送り調節パイプ	FEED ADJUSTING PIPE
19	13416	1	滚花螺母	ローレット	KNURLING TOOL
20	8157	1	弹簧	スプリング	SPRING
21	8158	1	小珠	ボール	BALL
22	18027	1	送量调接柄	送り調節レバー	FEED REVERSE LEVER
23	18028	2	螺丝	止ねじ(小)	SET SCREW M5X0.8 L=5.0
24	10806	1	手柄复位弹簧	バックレバースプリング	FEED REVERSE LEVER SPRING
25	13419	1	弹簧挂	スプリング掛	SPRING HOOK
26	15076	1	开口销	割ピン	PIN

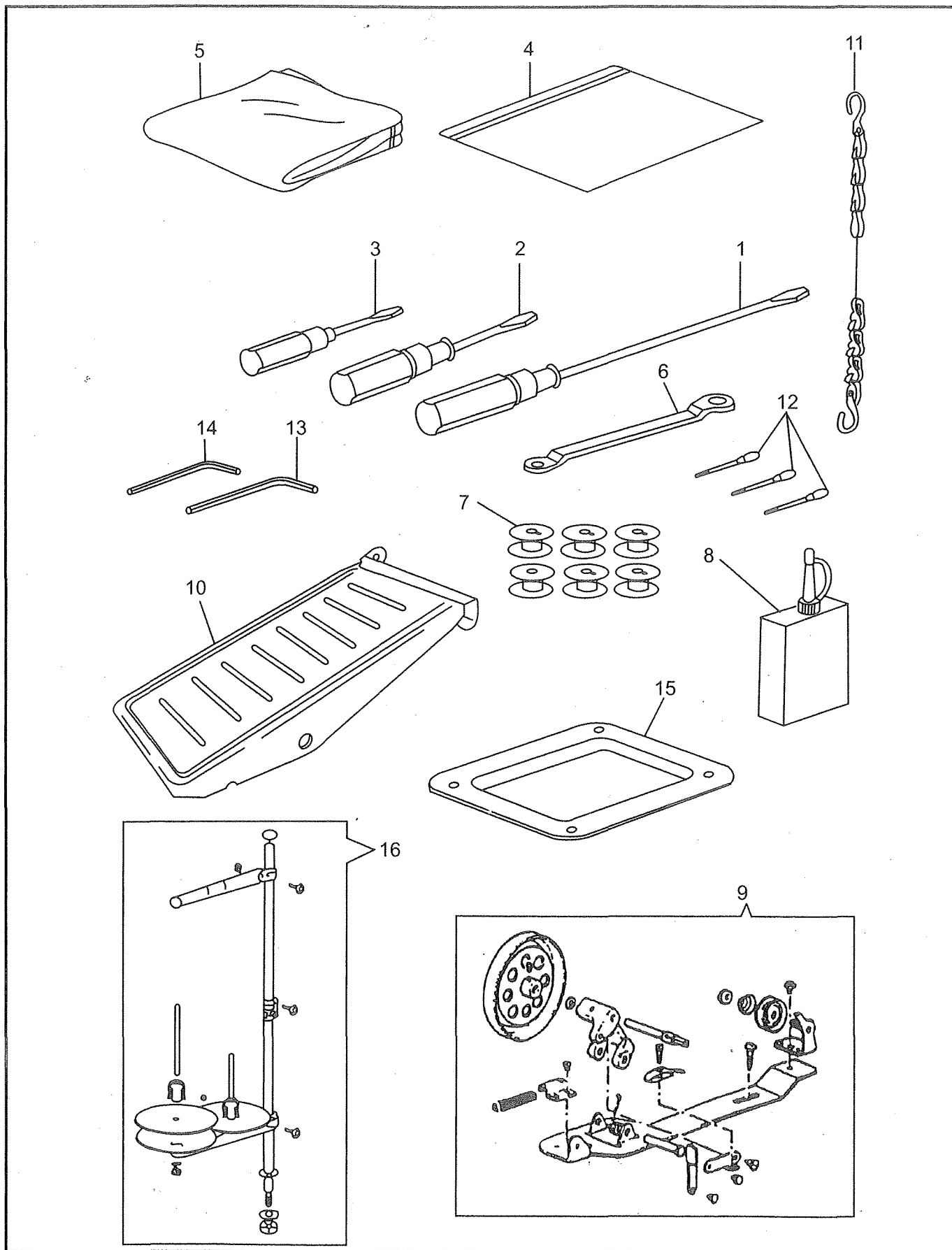

附属品部分 / 付属品関係 / Accessories

No.	零件号码 PARTS No.	数量 QTY	零件名称	品名	PARTS NAME
1	8118	1	螺丝刀(大)	ドライバー(大)	SCREW DRIVER (LARGE)
2	8120	1	螺丝刀(中)	ドライバー(中)	SCREW DRIVER (MIDDLE)
3	8121	1	螺丝刀(小)	ドライバー(小)	SCREW DRIVER (SMALL)
4	8132-B	1	零件包(带封口)	部品袋(チャッシ付)	ACCESSORIES PACK
5	8124	1	塑料罩盖	ビニールカバー	MACHINE COVER
6	10748	1	双头六角扳手	メガネレンチ	DOUBLE HEAD WRENCH
7	10656	6	梭心	ボビン	BOBBIN
8	8123	1	机油	油	OIL WITH OILIER
9	10734	1	卷线器组件	糸卷セット	BOBBIN WINDER COMPLETE
10	13098	1	脚踏板组件	ペダルセット	PEDAL COMPLETE
11	13079	1	金属链	くさり	CHAIN (100 M/M)
12	N0122	3	缝针DPX17 #22	針 DPX17 #22	MEEDLE DP X 17 #22
13	11487	1	内六角扳手	六角レンチ (3ミリ)	HEXAGON WRENCH (3MM)
14	11969	1	内六角扳手 (3mm)	六角レンチ (2.5ミリ)	HEXAGON WRENCH (2.5MM)
15	13089	1	油盘 (2.5mm)	油受	OIL PAN
16	35254	1	线架组件	糸立セット	THREAD UNWINDER COMPLETE

另売零件 / 別売品 / Parts available at extra charge

皮带罩壳 / ベルトカバー関係 / Belt cover

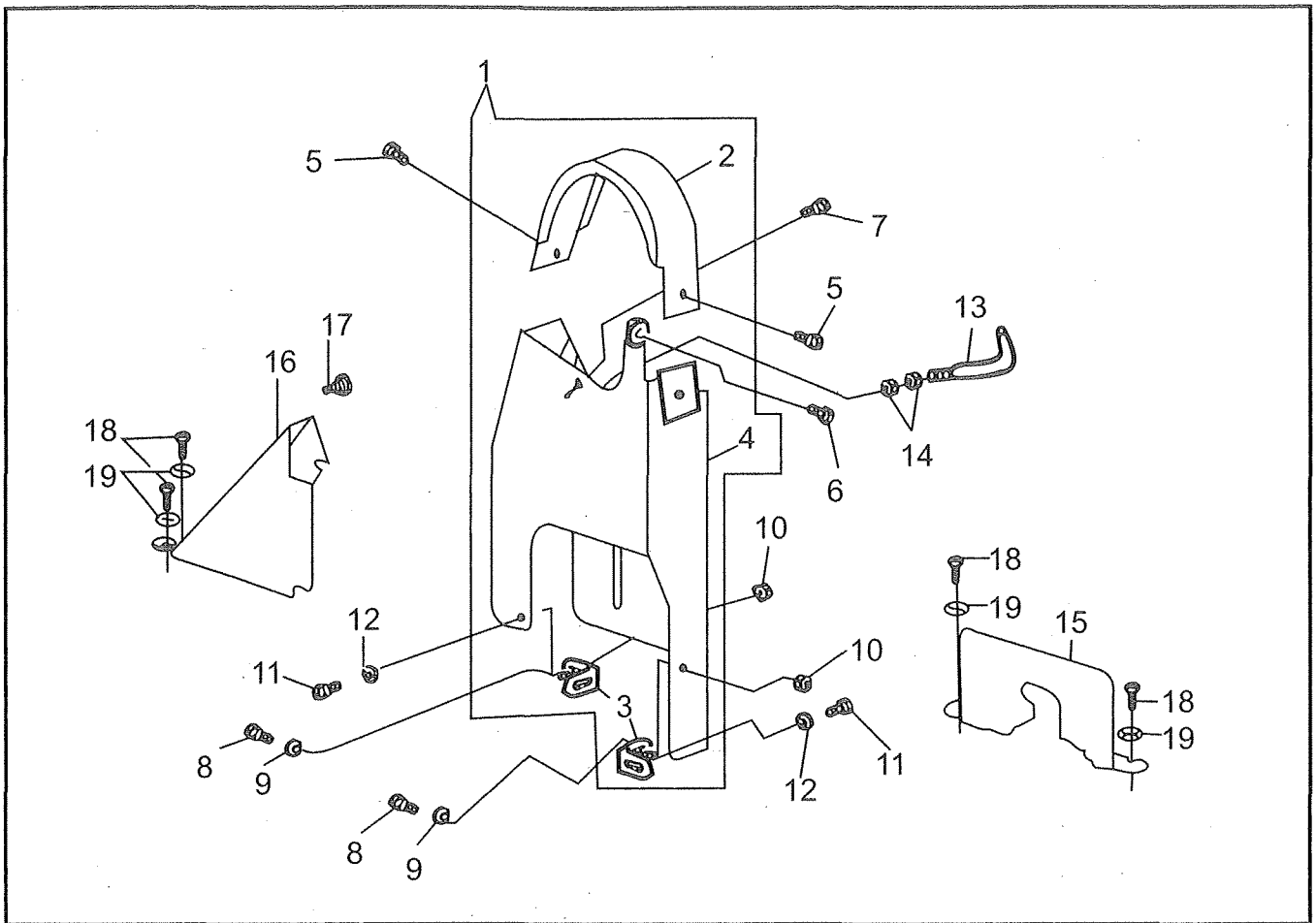

手指防护架 / フィンガーガード関係 / Finger guard

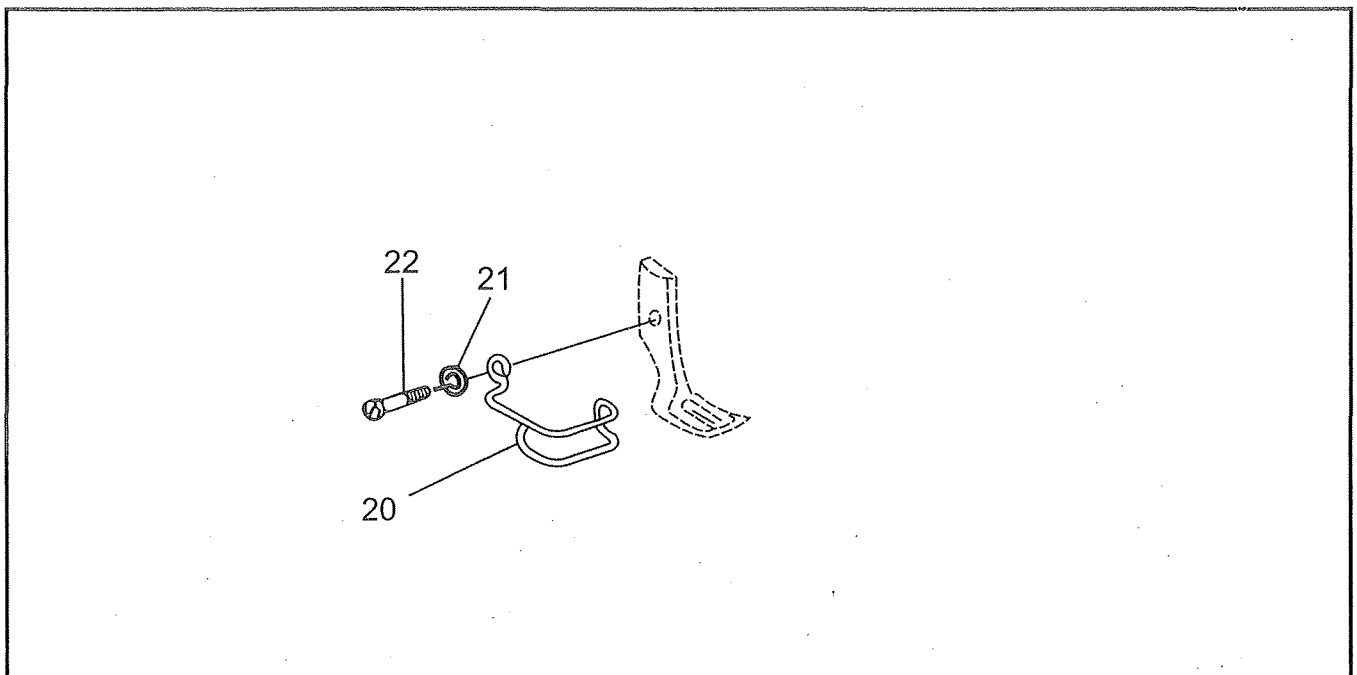

另卖零件 / 別売品 / Parts available at extra charge

皮带罩壳 / ベルトカバー関係 / Belt cover

No.	零件号码 PARTS No.	数量 QTY	零件名称	品名	PARTS NAME
1	13425C	1	皮带罩(组件)	ベルトガード(組)	BELT GUARD COMPLETE
2	13426	1	皮带罩上罩盖	ベルトガード上カバー	BELT GUARD TOP COVER
3	13427	2	扶助板	補助板	BELT GUARD SET PLATE
4	13425	1	皮带防护罩(主体)	ベルトガード(本体)	BELT GUARD(BODY)
5	6339	2	螺丝	止ねじ	SCREW 1/8X44 L=4.0
6	11162	1	螺丝	止ねじ	SCREW 3.4X36 L=5.4
7	10559	1	螺丝(A)	止ねじ(A)	SCREW 4.5X32 L=8.0
8	14024	2	螺丝	止ねじ	SCREW 3/16X32 L=9.5
9	16287	2	垫圈	ワッシャー	WASHER
10	50103	2	螺母	ナット	NUT
11	10561	2	螺丝	止ねじ(下)	SCREW 11/64X32 L=6.5
12	11142	2	垫圈	ワッシャー	WASHER
13	17372	1	检测器定位杆	検出器支え棒	SYNCHRONIZER SUPPORT ROD
14	50409	2	螺母	ナット	NUT
15	13429	1	防护罩扶助板	ベルトガード補助板	BELT GUARD (BOTTOM)SIDE COVER
16	13428	1	防护罩扶助板	ベルトガード補助ガード	BELT GUARD (BOTTOM)COVER
17	11830	1	螺丝	止ねじ	SCREW
18	10677	1	垫圈	ワッシャー	WASHER
19	15081	4	不螺丝	木ねじ	WOOD SCREW
20	16287	4	垫圈	ワッシャー	WASHER

手指防护架 / フィンガーガード関係 / Finger guard

No.	零件号码 PARTS No.	数量 QTY	零件名称	品名	PARTS NAME
21	10937	1	手指防护架	フィンガーガード	FINGER GUARD
22	10677	1	垫圈	ワッシャー	WASHER
23	10749A	1	安全架固定螺丝	外押え止(フィンガーガード用)	SCREW 9/64"X40L=11.5(FOR FINGER GUARD)

**INSTRUCTIONS AND
PARTS MANUAL**

CONSEW USA

Carlstadt, NJ / Miami, FL / Los Angeles, CA