

STANDS FOR EVERY MACHINE

Stands are available: Knocked Down (KD) - assembly required, Fully Assembled or Fully Assembled with sewn-off head.

Overview of Sewing Machine Stands

Parts of a stand: 1. The Legs ("K" leg, T-leg, "H" leg)
2. The table. 3. The motor (& on/off switch) 4. The foot treadle. 5. Links for the foot treadle.
6. Accessories (pedals, knee lift, lights, accessory drawer, etc.)

One cannot put a sewing machine on just the legs. What is needed is a "Complete" stand setup. The table is usually cut out with a pattern that fits the specific machine that one is putting on the stand. The motor must be placed in the correct position so the pulleys of the motor and machine line up and a belt can connect them. Below the table there can be a treadle with a rod connecting it to the motor or an electronic pedal switch controlling the motor depending on which type of motor you are using. There may also be a knee pad lever for foot lift or other switches depending on the type of machine and what control functions it has.

In addition to the basics that comprise a working COMPLETE STAND, there are many accessories available including: lighting, thread holders, measuring tape, etc. "K" leg, T-leg, "H" leg, Sunken and Space-saver stands available assembled or knocked-down (you assemble.) We have "Complete Stands" that come with all the necessary basics: the legs, table, motor, switch, pedals. We have the appropriate stand for your machine! Tell us what machine it is for and what you need to sew and we will tell you what stand and accessories you need.



STANDS FOR EVERY MACHINE

Stands are available: Knocked Down (KD) - assembly required, Fully Assembled or Fully Assembled with sewn-off head.

(note: "Sewn-off" just means someone sewed a small piece of fabric to confirm that the machine is sewing)

30" long arm sewing machine in a extended table H-Leg Stand



Overlock machine set up in a K-Leg Stand

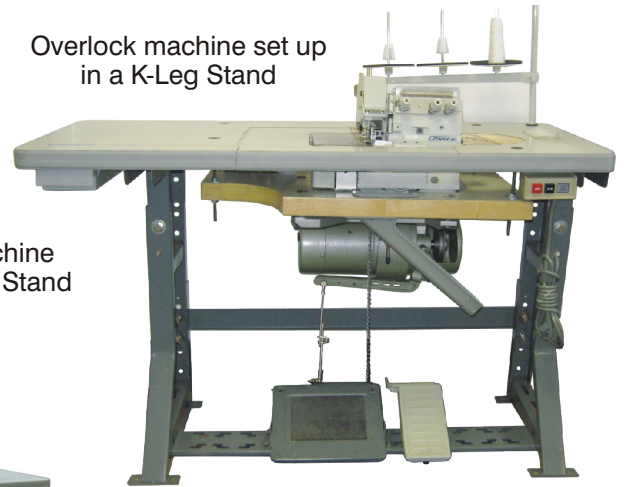

Heavy-duty cylinder bed machine shown set up on Space-Saver Stand



Sewing machine in a K-Leg Stand



Casters may be installed on stands (A T-Leg stand shown here with casters)



These are just some examples of popular stands. Call for your specific stand needs. Also available: Legs, Tables, Motors, Switches, Belts, Lights, Thread Stands, etc.

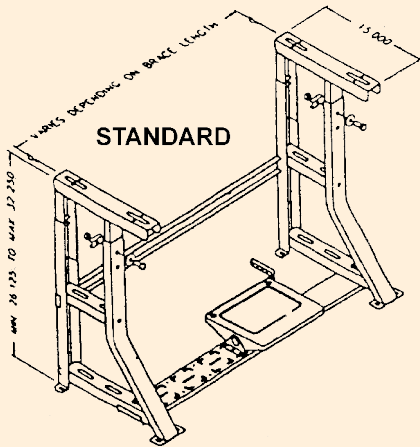

"K" STYLE

STANDARD	WIDTH	HEIGHT ADJ.
302	15	26-1/8 to 32-1/4
302HB	17	35-3/4 to 42

X-WIDE	WIDTH	HEIGHT ADJ.
302XW	23	26-1/8 to 32-1/4
302XWHB	23	34 to 41-3/4

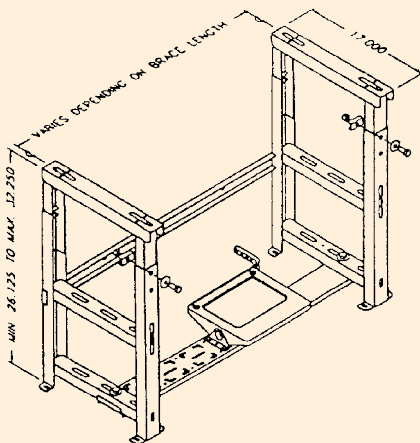

"H" STYLE

H-LEG	WIDTH	HEIGHT ADJ.
301H	17	26-1/8 to 32-1/4
301HB	17	35-3/4 to 42
301HXW	24	26-1/8 to 32-1/4
301HXXW	26	26-1/8 to 32-1/4

SPACE SAVER LEGS

ITEM #
302SS
WIDTH
18-3/4
HEIGHT
28-3/8

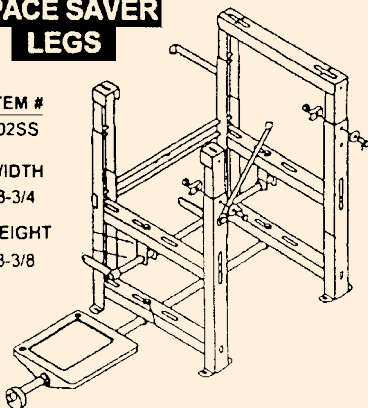

Note: Legs are usually in Gray

Premier "T"-Leg Stands
a cost effective stand solution

Stands include:

- Table Top with ruler imprint and machine cutout
- Legs with braces
- (Locking Wheels - Optional)
- Foot Treadle
- Adjustable Treadle Rod
- Motor (1/2HP, 110VAC Clutch Motor)
- Switch & Power Cable
- Accessory Drawer

When ordering, you must specify for which machine the stand will be used.
Long-Arm or Submerged machines require different stands and there are many options.

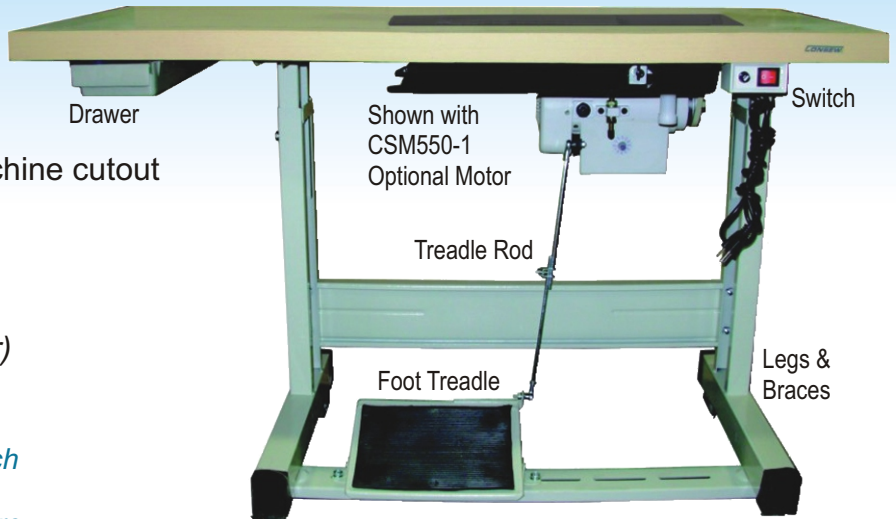

- Stands may be ordered:**
- Unassembled (Knocked-Down)
 - Assembled
 - Assembled and Sewn-off (drop-in machine-ready)

- OPTIONS:**
- CSM550-1 Servo Motor
 - CSM1000/ CSM2000(220v) Servo Motor
 - CSM1001/ CSM2001(220v) Servo Motor
(All Servo Motors are listed on pages 128-129)
 - Heavy Duty "K" Stand
 - Table Top with T-Molding
 - FDG-22 Light
 - DSB60C Light
 - LED Lighting options, pgs 126-127

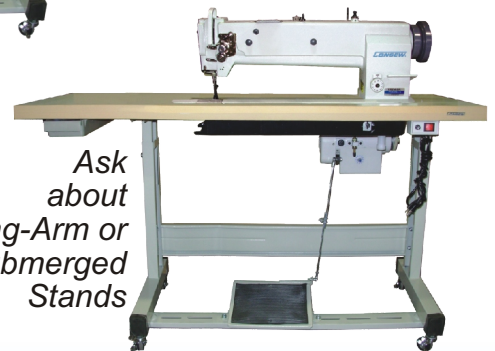

Ask about Long-Arm or Submerged Stands

OPTIONS:

PREMIER CSM550-1
ELECTRONIC SERVO MOTOR
550 Watts, 3/4 HP,
110 V, 60 Hz, 1-Phase, 0-3600 RPM
(220 V available)

Go to page 129 for details



CSM 1000 / CSM1001 Series...
3/4 HP (550 Watt) Brushless Servo Motors
Speed: 0 - 4200 RPM 110v and 220v
Energy Efficient - Saves up to 70% Electricity
(Also available in 1 HP (750Watt), Speed: 0-3600 RPM)

Go to page 128 for details



CSM1000



CSM1001 comes with Needle Positioner (Synchronizer)

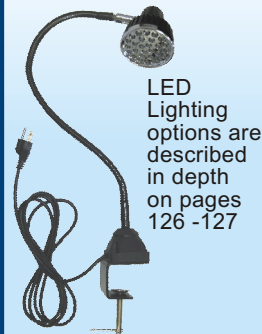

LED Lighting options are described in depth on pages 126 -127

DSB60C
FDG-22

For Traditional Lighting call your dealer. Consew has a complete line.