

SEWING MACHINE LEG DIAGRAMS

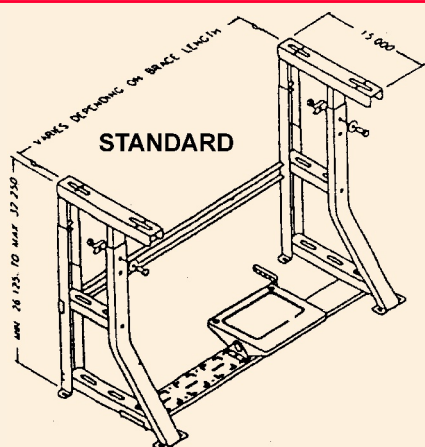

"K" STYLE

STANDARD WIDTH HEIGHT ADJ.

302	15	26-1/8 to 32-1/4
302HB	17	35-3/4 to 42

X-WIDE WIDTH HEIGHT ADJ.

302XW	23	26-1/8 to 32-1/4
302XWHB	23	34 to 41-3/4

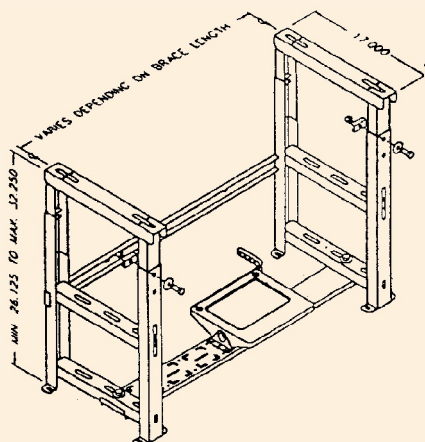

"H" STYLE

H-LEG WIDTH HEIGHT ADJ.

301H	17	26-1/8 to 32-1/4
301HB	17	35-3/4 to 42
301HXW	24	26-1/8 to 32-1/4
301HXXW	26	26-1/8 to 32-1/4

SPACE SAVER LEGS

ITEM #
302SS
WIDTH
18-3/4
HEIGHT
28-3/8

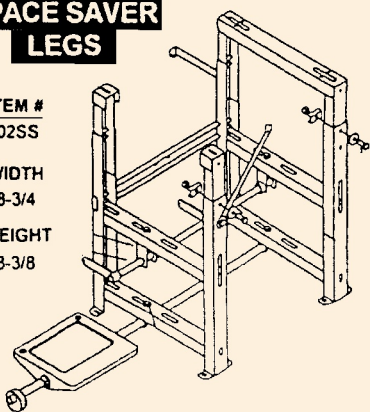

Note: Legs are usually in Gray

STANDS FOR EVERY MACHINE

Stands are available: Knocked Down (KD) - assembly required, Fully Assembled or Fully Assembled with sewn-off head. (See page 133 for the new line of Premier stands.)

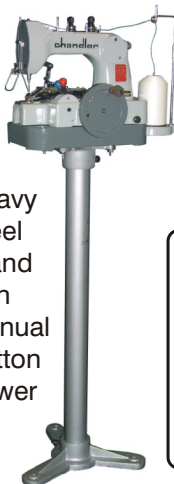

Heavy Steel Stand with Manual Button Sewer



Available Option: Speed Reducer

30" long arm sewing machine in a extended table H-Leg Stand

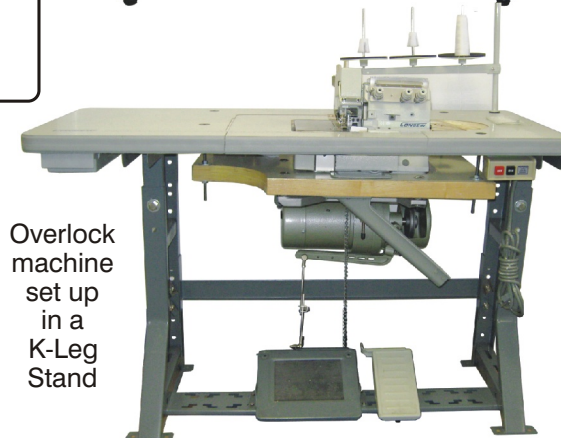

Overlock machine set up in a K-Leg Stand



Heavy-duty cylinder bed machine shown set up on Space-Saver Stand



Sewing machine in a K-Leg Stand



Casters may be installed on stands (A T-Leg stand shown here with casters)

"U" cut out table tops also available for cylinder arms.



These are just some examples of popular stands. Call for your specific stand needs. Also available: Legs, Tables, Motors, Switches, Belts, Lights, Thread Stands, etc.

Since 1898
CONSEW[®]
 PREMIER[®] STANDS

Stands include:

- Table Top with ruler imprint and machine cutout
- Legs with braces
- (Locking Wheels - Optional)
- Foot Treadle
- Adjustable Treadle Rod
- Motor (1/2HP, 110VAC Clutch Motor)
- Switch & Power Cable
- Accessory Drawer

When ordering, you must specify for which machine the stand will be used.
 Long-Arm or Submerged machines require different stands and there are many options.

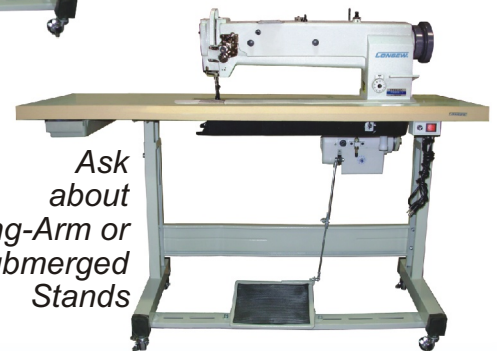
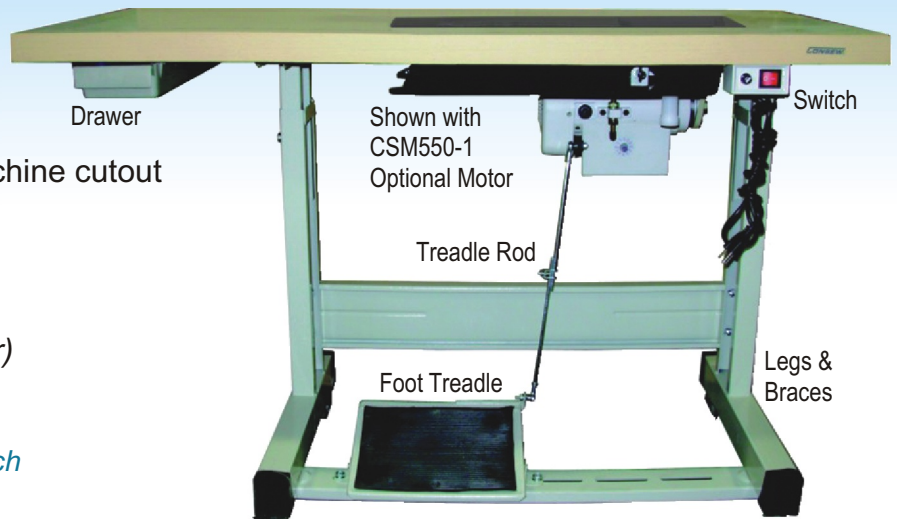

Available Option:
 Speed Reducer

Ask about Long-Arm or Submerged Stands

Stands may be ordered:

- Unassembled (Knocked-Down)
- Assembled
- Assembled and Sewn-off (drop-in machine-ready)

OPTIONS:

CSM550-1 Servo Motor
 CSM1000/ CSM2000^(220v) Servo Motor
 CSM1001/ CSM2001^(220v) Servo Motor
 (All Servo Motors are listed on pages 128-129)
 Heavy Duty "K" Stand
 Table Top with T-Molding

FDG-22 Light
 DSB60C Light
 LED Lighting options, pgs 126-127

OPTIONS:

PREMIER CSM550-1
 ELECTRONIC SERVO MOTOR
 550 Watts, 3/4 HP,
 110 V, 60 Hz, 1-Phase, 0-3600 RPM
 (220 V available)

Go to page 129 for details



CSM 1000 / CSM1001 Series...
 3/4 HP (550 Watt) Brushless Servo Motors
Speed: 0 - 4200 RPM 110v and 220v
 Energy Efficient - Saves up to 70% Electricity
 (Also available in 1 HP (750Watt), Speed: 0-3600 RPM)

Go to page 128 for details



CSM1000

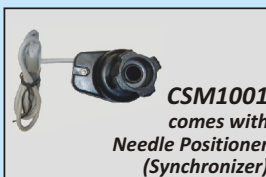

CSM1001 comes with Needle Positioner (Synchronizer)

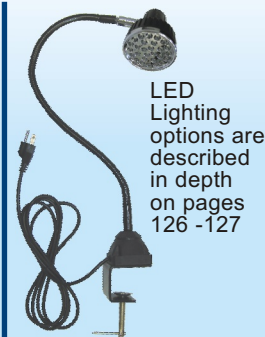

LED Lighting options are described in depth on pages 126 -127

DSB60C
FDG-22

For Traditional Lighting call your dealer. Consew has a complete line.

