

CONSEW[®]

MODEL 2040

PARTS BOOK



MODEL : 2040

目次	CONTENT	PAGE
A. 本體關係	FRAME & MISCELLANEOUS COVER COMPONENTS	2-3
B. 上軸關係	MAIN SHAFT COMPONENTS	4-5
C. 針棒・天秤關係	NEEDLE BAR & THREAD TAKE-UP LEVER COMPONENTS	6-7
D. 針棒搖擺關係	NEEDLE BAR ROCKING MOTION MECHANISM COMPONENTS	8-9
E. 上部送料關係	UPPER FEED MECHANISM COMPONENTS	10-11
F. 押脚・脚弓關係	PRESSURE BAR & KNEE LIFTER COMPONENTS	12-13
G. 下部送料關係	LOWER FEED MECHANISM COMPONENTS	14-15
H. 縫目調整關係	FEED ADJUSTMENT MECHANISM COMPONENTS	16-17
I. 下軸關係	HOOK DRIVE SHAFT COMPONENTS	18-21
J. 縫線壓力調節關係	UPPER THREAD TENSION REGULATOR MECHANISM COMPONENTS	22-23
K. 附件	ACCESSORIES	24-25
L. 皮帶蓋關係	BELT COVER COMPONENTS	26-27
M. 零件號碼與頁數對照表	NUMERICAL PARTS-LIST	28-30

A. 2040 本體關係 FRAME & MISCELLANEOUS COVER COMPONENTS

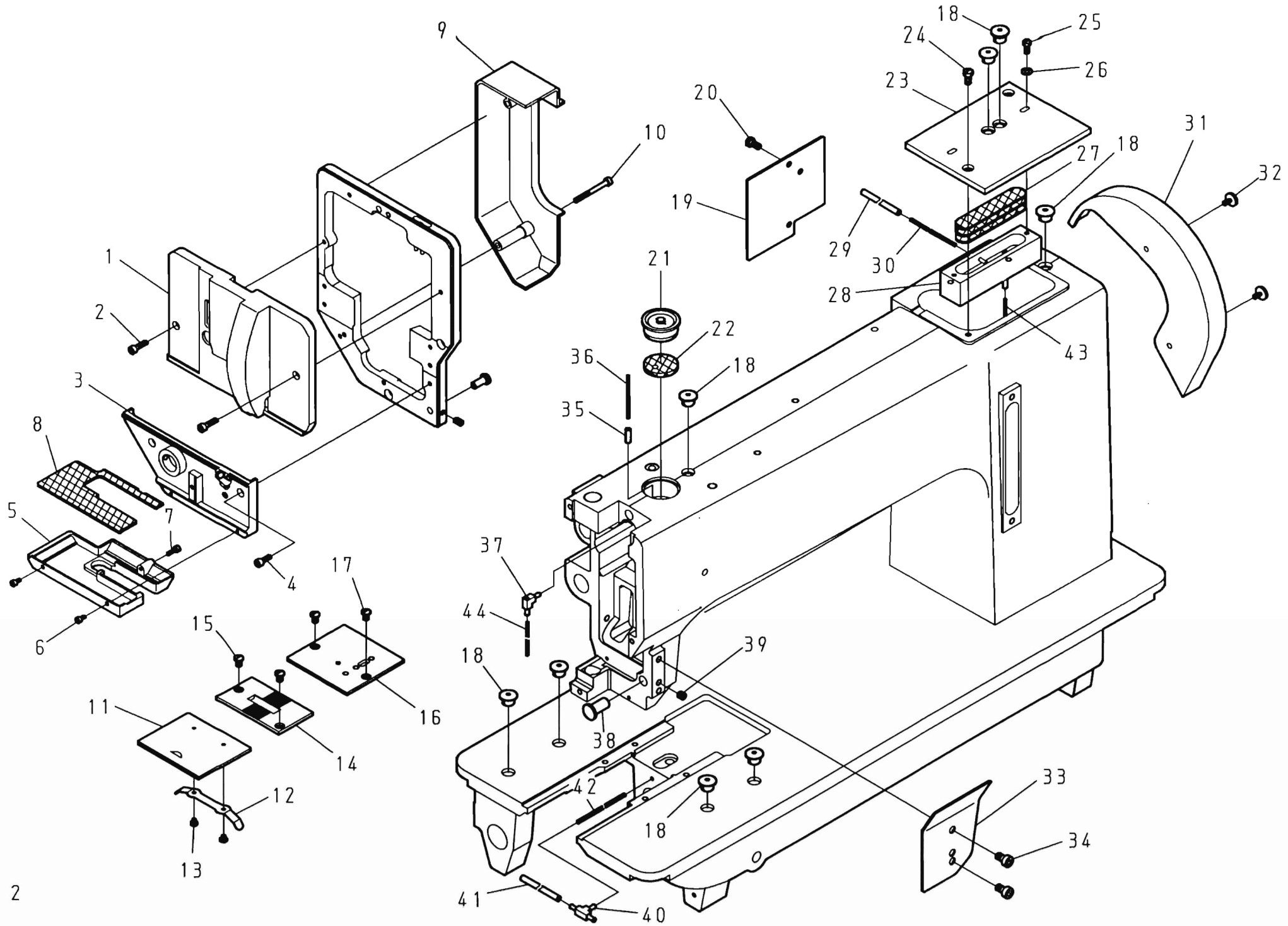

A. 2040 本體關係 FRAME & MISCELLANEOUS COVER COMPONENTS

REF.No	NOTE	零件號碼 Part No.	零件名稱	Name of Part	件數 Q'TY	備註 Remarks
1		2040111000	面板	Face Plate	1	
2		ZMJ04003	螺絲	Screw M4X0.7*15	2	
3		2040110900	面板(下)	Face Plate	1	
4		ZMJ04005	螺絲	Screw M4X0.7*12	2	
5		2040351900	保護塵蓋	Dust Stopper Plate	1	
6		ZMJ03010	螺絲	Screw M3X0.5*6	2	
7		ZMJ03001	螺絲	Screw M3X0.5*10	1	
8		XB400063	油綿	Felt	1	
9		204011100C	保護蓋	Cover	1	
10		ZMJ04020	螺絲	Screw M4X0.7*40	2	
11		2040111800	角板	Slide Plate	1	
12		2040111700	簧片	Slide Plate Spring	1	
13		ZMB03001	螺絲	Screw M3X0.5*4	2	
14		2040111300	針板	Throat Plate	1	
15		ZMB05003	螺絲	Screw M5X0.8*7	2	
16		2040111600	角板(右)	Slide Plate (Right)	1	
17		ZMB05003	螺絲	Screw M5X0.8*7	2	
18		A1077-0A	橡膠塞	Oil Cap	8	
19		2040111200	橫蓋	Arm Side Cover	1	
20		ZMB05004	螺絲	Screw M5X0.8*10	2	
21		2040350200	橡膠塞	Oil Cap	1	
22		XB130001	油綿	Felt	1	
23		2040111100	上蓋	Top Cover	1	
24		ZMB05004	螺絲	Screw M5X0.8*10	2	
25		ZMB04016	螺絲	Screw M4X0.7*10	2	
26		WA049003	平墊圈	Washer	2	
27		XB215001	油綿	Felt	3	
28		2040351504	油槽	Oil tank	1	
29		XP300200	油管線	Oil Tube	1	
30		XA200400	油線	Oil Wick	1	
31		2040335800	皮帶蓋	Cover	1	
32		ZMB04013	螺絲	Screw M4X0.7*8	2	
33		2040113100	橫蓋	Arm Side Cover	1	
34		ZMJ06001	螺絲	Screw M6X1.0*8	2	
35		YD040014A	銷	Spring Pins	1	
36		XA200280	油線	Oil Wick	1	
37		2040353604	油管接頭	Oil Pipe Joint	1	
38		2040270400	銷	Pin	1	
39		ZMH06008	螺絲	Screw M6X1.0*6	1	
40		2040353804	油管接頭	Oil Pipe Joint	1	
41		XP300150	油管線	Oil Tube	1	
42		XA200800	油線	Oil Wick	1	
43		XA200180	油線	Oil Wick	1	
44		XA200150	油線	Oil Wick	1	

B. 2040 上軸関係 MAIN SHAFT COMPONENTS

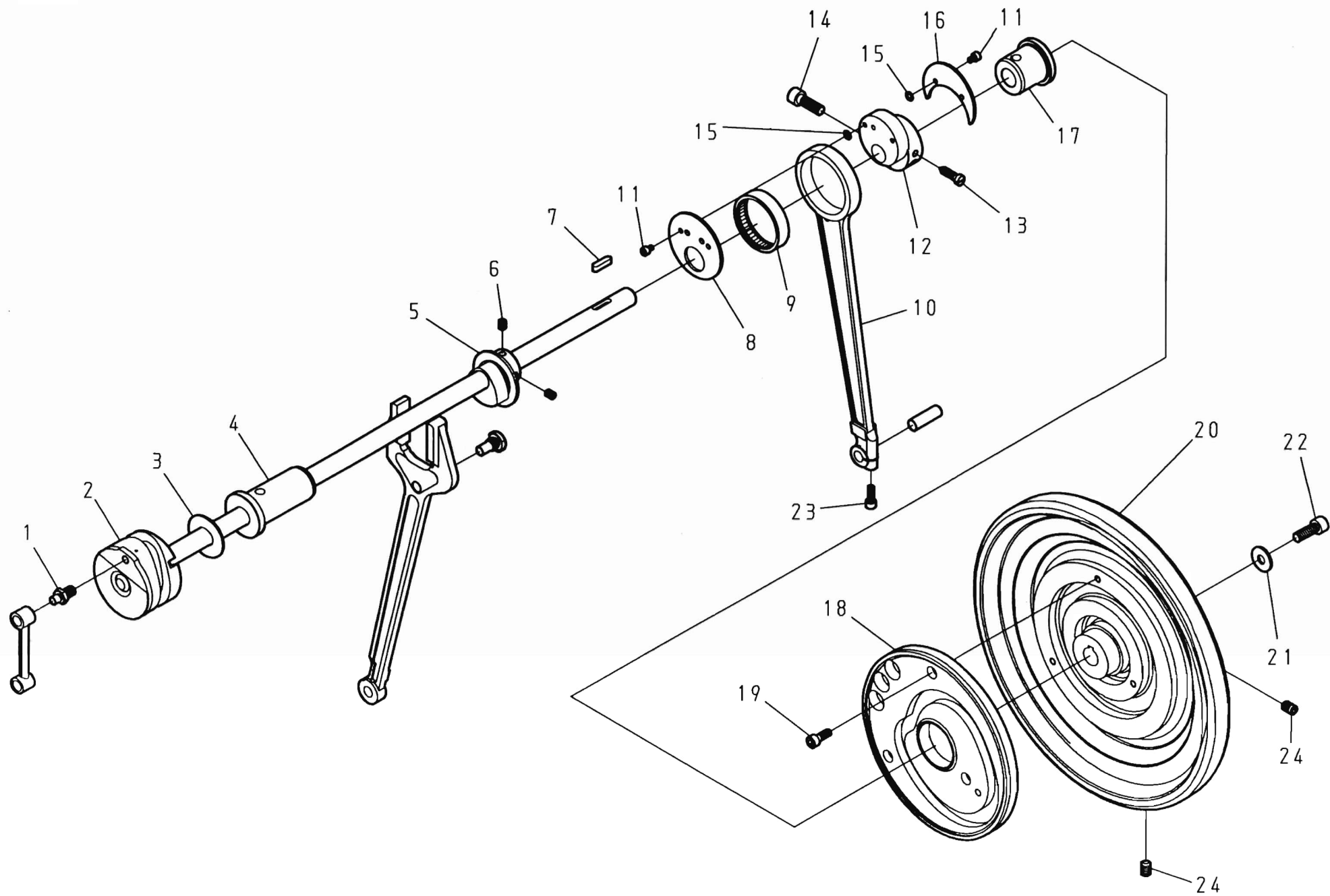

B. 2040 上軸關係 MAIN SHAFT COMPONENTS

REF.No	NOTE	零件號碼 Part No.	零件名稱	Name of Part	件數 Q'TY	備註 Remarks
1		2040121300	針棒連接軸	Needle Bar Crank Shaft	1	
2		2040120104	上軸(組)	Main Shaft Asm.	1	
3		WH216002	平墊圈	Washer	1	
4		2040120200	上軸套管(左)	Main Shaft Bushing,Front	1	
5		2040122000	偏心輪	Feed Cam	1	
6		ZMH06003	螺絲	Screw M6X1.0*8	2	
7		KC0305520	鍵	Key	1	
8		204018200A	側板	Side Plate	1	
9		BNHK4512	軸承	Needle Bearing	1	
10		2040181800	動桿	Connecting Rod	1	
11		ZMJ04008	螺絲	Screw M4X0.7*6	4	
12		2040181900	偏心輪	Con-Rod Eccentric Cam	1	
13		ZMB06020	螺絲	Screw M6X1.0*22	1	
14		ZMJ08011	螺絲	Screw M8X0.75*25	1	
15		WA040026	平墊圈	Washer	4	
16		204018200B	側板	Side Plate	1	
17		2040120400	上軸套管(右)	Main Shaft Bushing,Rear	1	
18		2040144400	偏心輪	Driving Cam	1	
19		ZMJ06009	螺絲	Screw M6X1.0*18	3	
20		2040122300	皮帶輪	Hand Wheel	1	
21		WA089004	平墊圈	Washer	1	
22		ZMJ08003	螺絲	Screw M8X1.25*22	1	
23		ZMJ05003	螺絲	Screw M5X0.8*15	1	
24		ZMH08002	螺絲	Screw M8X1.25*12	2	

C. 2040 針棒・天秤關係 NEEDLE BAR & THREAD TAKE-UP LEVER COMPONENTS

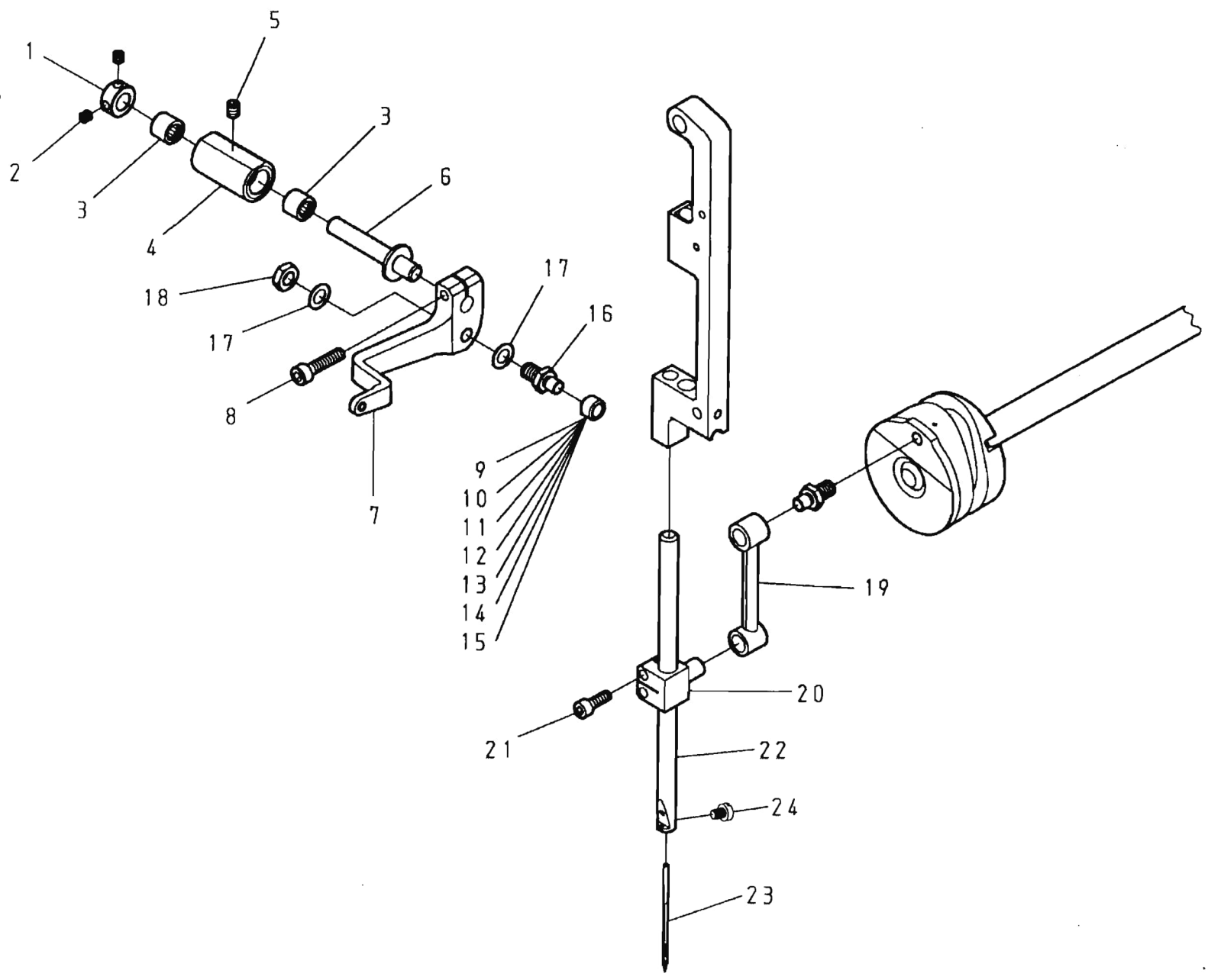

C. 2040 針棒·天秤關係 NEEDLE BAR & THREAD TAKE-UP LEVER COMPONENTS

REF.No	NOTE	零件號碼 Part No.	零件名稱	Name of Part	件數 QTY	備註 Remarks
1		TC09008200	定環	Thrust Collar	1	
2		ZMH05001	螺絲	Screw M5X0.8*5	2	
3		BNHK0910B	軸承	Needle Bearing	2	
4		2040192300	套管	Bushing	1	
5		ZMH06003	螺絲	Screw M6X1.0*8	1	
6		2040192100	軸	Shaft	1	
7		2040190104	天秤(結合)	Thread Take Up Lever Com.	1	
8		ZMJ05017	螺絲	Screw M5X0.8*25	1	
9	#01	2040190210	滾仔	Roller	(1)	
10	#01	2040190220	滾仔	Roller	(1)	
11		2040190230	滾仔	Roller	1	
12	#01	2040190240	滾仔	Roller	(1)	
13	#01	2040190250	滾仔	Roller	(1)	
14	#01	2040190260	滾仔	Roller	(1)	
15	#01	2040190270	滾仔	Roller	(1)	
16		2040190300	滾仔固定軸	Roller Stud	1	
17		WA080022	平墊圈	Washer	2	
18		ZML08004	螺帽	Nut M8X1.25	1	
19		2040121000	針棒連接器	Needle Bar Crank Rod	1	
20		2040140900	針棒鉗	Needle Bar Connection	1	
21		ZMJ05003	螺絲	Screw M5X0.8*15	2	
22		2040140100	針棒	Needle Bar	1	
23		IN794#200	針	Needle (794 Nm=200)	1	
24		ZMB04093	螺絲	Screw M4X0.5*5.5	1	

Note(注記)#01----- Selective parts 選択部品

D. 2040 針棒搖擺關係 NEEDLE BAR ROCKING MOTION MECHANISM COMPONENTS

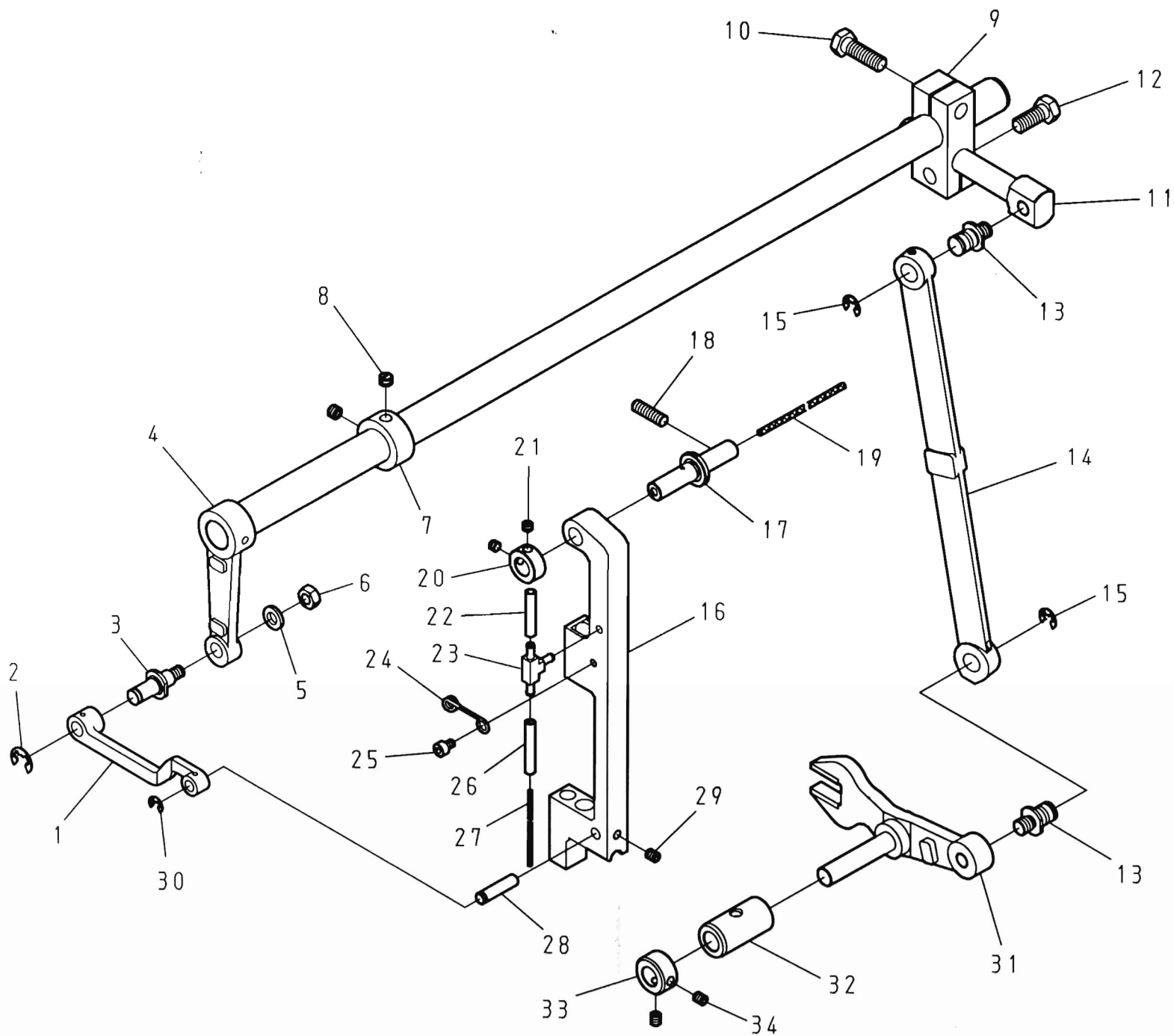

D. 2040 針棒搖擺關係 NEEDLE BAR ROCKING MOTION MECHANISM COMPONENTS

REF.No	NOTE	零件號碼 Part No.	零件名稱 Name of Part	件數 Q'TY	備註 Remarks
1		2040143100	搖軸連桿 ----- Rod -----	1	
2		RE000070	E扣環 7 ----- Retaining Rings- E Type 7 -----	1	
3		ZMK06025	螺絲 ----- Hinge Screw -----	1	
4		2040142304	中軸連桿(前)(結合) --- Driving Shaft Rod, Rear Com. ---	1	
5		WA06008	平墊圈 ----- Washer -----	1	
6		ZML06001	螺帽 ----- Nut M6X1.0 -----	1	
7		LG4043-0A	定環 ----- Thrust Collar -----	1	
8		ZSA16010	螺絲 ----- Screw 1/4-40*4.5 -----	2	
9		4410142400	中軸連桿(後) ----- Driving Shaft Rod, Rear -----	1	
10		ZSD20009	螺絲 ----- Screw 5/16-18*25 -----	1	
11		2040141900	中軸連桿銷(後) ----- Driving Shaft Rear Arm Pin -----	1	
12		ZSD20011	螺絲 ----- Screw 5/16-18*19 -----	1	
13		ZMK08016	螺絲 ----- Hinge Screw -----	2	
14		2040271100	連桿 ----- Lenghtwise Feed Rod -----	1	
15		RE000080	E扣環 8 ----- Retaining Rings- E Type 8 -----	2	
16		2040270100	針棒座 ----- Frame Driving Base -----	1	
17		2040270200	針棒座軸 ----- Frame Driving Base Shaft -----	1	
18		ZMH06016	螺絲 ----- Screw M6X1.0*20 -----	1	
19		XA200300	油線 ----- Oil Wick -----	1	
20		TC09508200	定環 ----- Thrust Collar -----	1	
21		ZMH05006	螺絲 ----- Screw M5X0.8*4 -----	2	
22		XP300045	油管線 ----- Oil Tube -----	1	
23		2040353804	油管接頭 ----- Oil Pipe Joint -----	1	
24		2040352900	油管支持片 ----- Pipe Holder -----	1	
25		ZMJ04008	螺絲 ----- Screw M4X0.7*6 -----	1	
26		XP300055	油管線 ----- Oil Tube -----	1	
27		XA300460	油線 ----- Oil Wick -----	1	
28		2040271300	銷 ----- Pin -----	1	
29		ZMH05002	螺絲 ----- Screw M5X0.8*6 -----	1	
30		RE000040	E扣環 4 ----- Retaining Rings- E Type 4 -----	1	
31		2040169204	送料台柄 ----- Feed Connection Crank -----	1	
32		2040273000	套管 ----- Bushing -----	1	
33		TC10010200	定環 ----- Thrust Collar -----	1	
34		ZMH05002	螺絲 ----- Screw M5X0.8*6 -----	2	

E. 2040 上部送料関係 UPPER FEED MECHANISM COMPONENTS

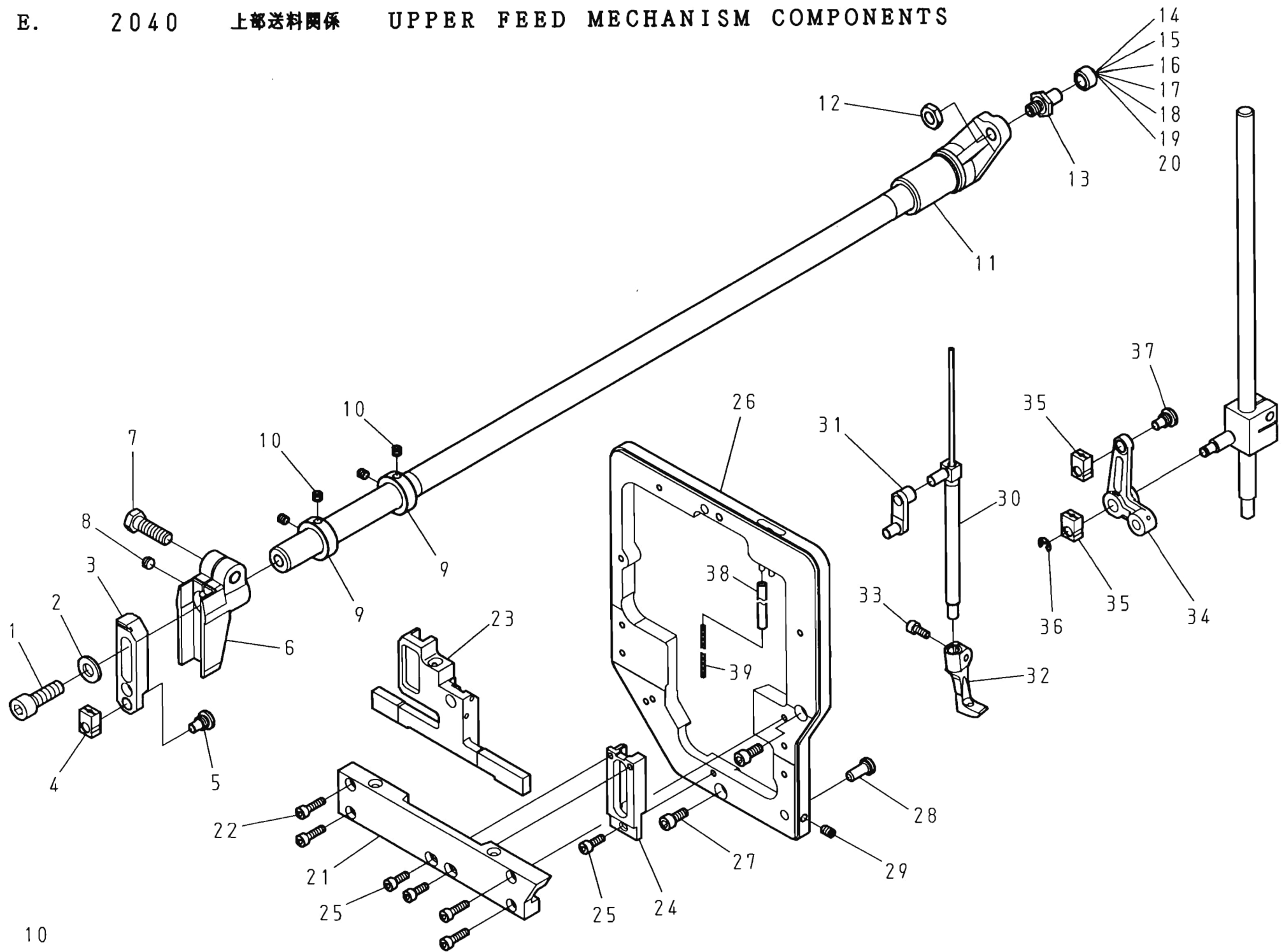

E. 2040 上部送料關係 UPPER FEED MECHANISM COMPONENTS

REF.No	NOTE	零件號碼 Part No.	零件名稱	Name of Part	件數 Q'TY	備註 Remarks
1		ZMJ08006	螺絲	Screw M8X1.25*25	1	
2		WA080007	平墊圈	Washer	1	
3		2040142700	滑塊	Slide Brock	1	
4		2040148000	滑塊	Slide Brock	1	
5		ZMB08005	螺絲	Hinge Screw	1	
6		2040144600	上送軸柄	Driving Shaft Arm,Front	1	
7		ZSD20009	螺絲	Screw 5/16-18*25	1	
8		ZSA16020	螺絲	Screw 1/4-40*5.5	1	
9		TC16008200	定環	Thrust Collar	2	
10		ZMH05001	螺絲	Screw M5X0.8*5	4	
11		2040144704	上送軸曲柄(結合)	Driving Shaft Arm,Rear Com.	1	
12		ZML08004	螺帽	Nut M8 x 1.25	1	
13		ZMK08017	滾仔固定軸	Roller Stud	1	
14	#01	2040145410	滾仔	Roller	(1)	
15	#01	2040145420	滾仔	Roller	(1)	
16		2040145430	滾仔	Roller	1	
17	#01	2040145440	滾仔	Roller	(1)	
18	#01	2040145450	滾仔	Roller	(1)	
19	#01	2040145460	滾仔	Roller	(1)	
20	#01	2040145470	滾仔	Roller	(1)	
21		2040142500	導板	Guide Plate	1	
22		ZMJ04003	螺絲	Screw M4X0.7*15	4	
23		2040142900	滑塊	Slide Brock	1	
24		2040151100	導板	Guide Plate	1	
25		ZMJ04005	螺絲	Screw M4X0.7*12	3	
26		2040110604	面板土台(結合)	Face Plate Base Com.	1	
27		ZMJ05002	螺絲	Screw M5X0.8*12	2	
28		2040143700	銷	Pin	1	
29		ZMH05003	螺絲	Screw M5X0.8*8	1	
30		2040141704	中腳押棒(結合)	Vibrating Presser Bar Com.	1	
31		2040143300	押腳舉升連桿	Vibrating Presser Bar Link	1	
32		2040151000	內壓腳	Walking Foot	1	
33		ZMJ04002	螺絲	Screw M4X0.7*10	1	
34		2040143600	舉升曲臂連桿	Lifting Bell Crank	1	
35		2040148000	滑塊	Slide Brock	2	
36		RE000040	E扣環 4	Retaining Rings- E Type 4	1	
37		ZMB08005	螺絲	Hinge Screw	1	
38		XP300100	油管線	Oil Tube	1	
39		XA200360	油線	Oil Wick	1	

Note(注記)#01----- Selective parts 選擇部品

F. 2040 押脚・脚弓関係 PRESSURE BAR & KNEE LIFTER COMPONENTS

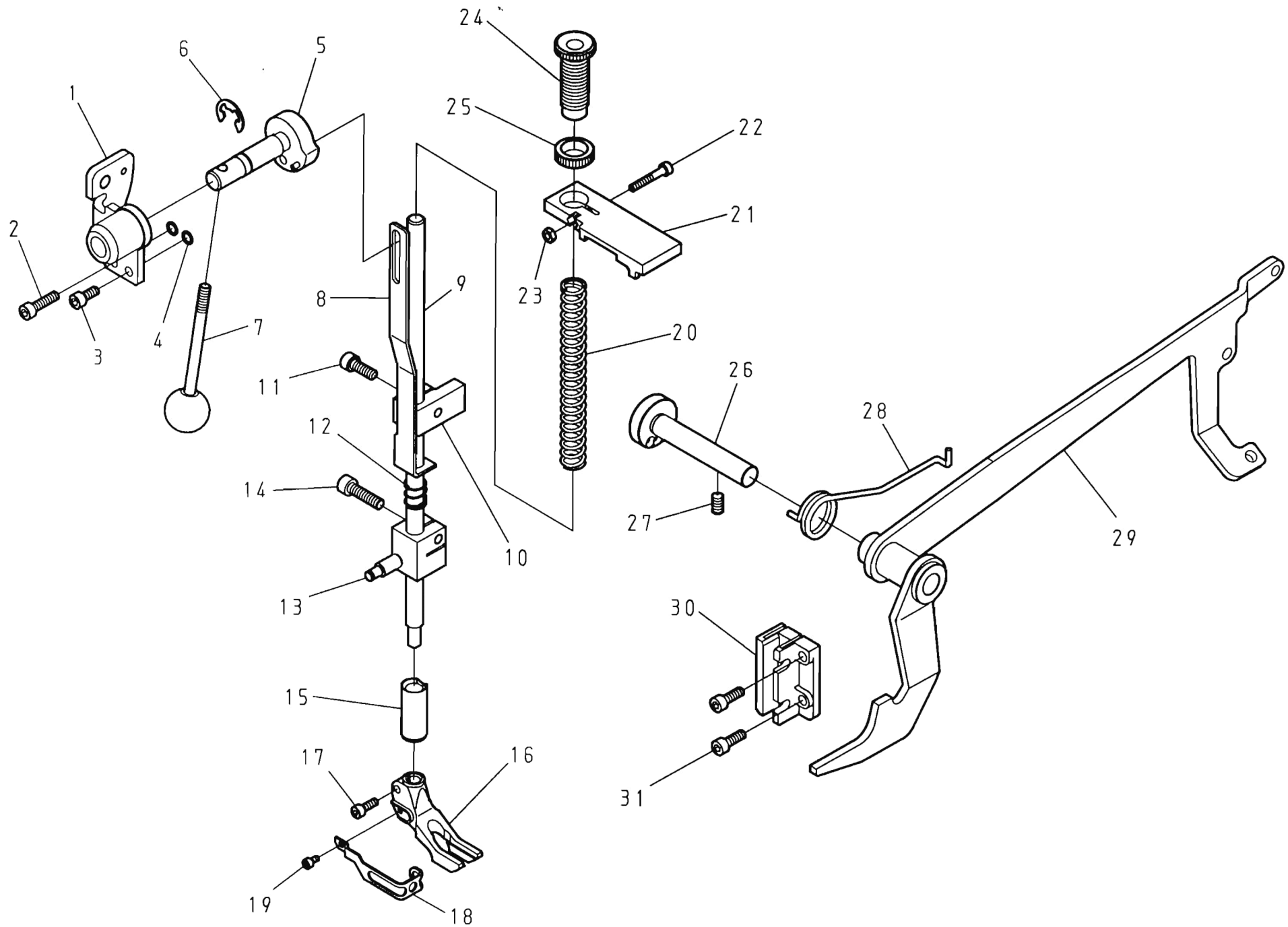

F. 2040 押脚·脚弓關係 PRESSURE BAR & KNEE LIFTER COMPONENTS

REF.No	NOTE	零件號碼 Part No.	零件名稱 Name of Part	件數 Q'TY	備註 Remarks
1		2040157104	支持台(結合) ----- Bracket Com. -----	1	
2		ZMJ05004	螺絲 ----- Screw M5X0.8*20 -----	1	
3		ZMJ05002	螺絲 ----- Screw M5X0.8*12 -----	1	
4		WA059006	平墊圈 ----- Washer -----	2	
5		2040150704	押棒偏心軸(結合) --- Hand Lifter Cam Com. ---	1	
6		RE000100	E扣環 10 ----- Retaining Rings- E Type 10 -----	1	
7		2040150804	押棒堤桿(結合) --- Hand Lifter Lever Com. ---	1	
8		2040340300	壓棒固定座 ----- Hand Lifter Link -----	1	
9		2040150100	押棒 ----- Presser Bar -----	1	
10		2040150500	押棒堤昇器 ----- Presser Bar Lifter -----	1	
11		ZMJ06009	螺絲 ----- Screw M6X1.0*18 -----	1	
12		2040340200	壓縮彈簧 ----- Spring -----	1	
13		2040143500	舉升曲臂連桿土台 --- Lifting Bell Crank Base ---	1	
14		ZMJ06006	螺絲 ----- Screw M6X1.0*23 -----	1	
15		2040150200	押棒套管 ----- Bushing -----	1	
16		2040143800	外壓脚 ----- Presser Foot -----	1	
17		ZMJ04005	螺絲 ----- Screw M4X0.7*12 -----	1	
18		2040152500	保護板 ----- Guard -----	1	
19		ZMJ03010	螺絲 ----- Screw M3X0.5*6 -----	1	
20		2040150400	壓縮彈簧 ----- Presser Spring -----	1	
21		2040159900	上蓋 ----- Top Cover -----	1	
22		ZMJ04004	螺絲 ----- Screw M4X0.7*25 -----	1	
23		ZML04006	螺帽 ----- Nut M4X0.7 -----	1	
24		4710150300	螺絲 ----- Screw -----	1	
25		4710151500	螺帽 ----- Nut -----	1	
26		2040341700	軸 ----- Shaft -----	1	
27		ZMH06023	螺絲 ----- Screw M6X1.0*12 -----	1	
28		2040342300	彈簧 ----- Spring -----	1	
29		2040150604	押脚抬高桿 ----- Foot Lifter Lifting Lever -----	1	
30		2040151700	導板 ----- Guide Plate -----	1	
31		ZMJ05003	螺絲 ----- Screw M5X0.8*15 -----	2	

G. 2040 下部送料関係 LOWER FEED MECHANISM COMPONENTS

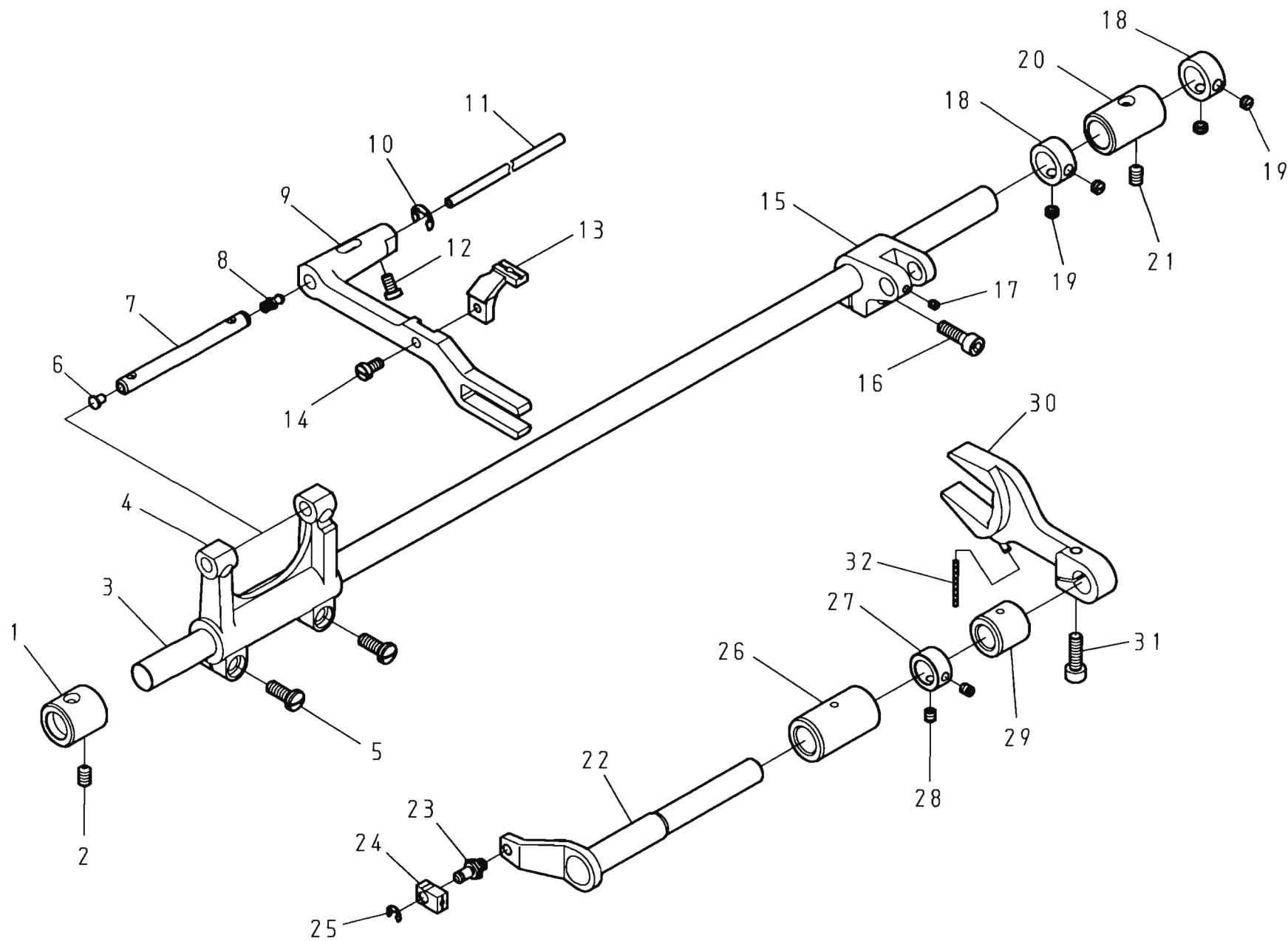

G. 2040 下部送料關係 LOWER FEED MECHANISM COMPONENTS

REF.No	NOTE	零件號碼 Part No.	零件名稱 Name of Part	件數 Q'TY	備註 Remarks
1		2040160600	搖動軸套管(前) --- Bushing, Front ---	1	
2		ZMH06010	螺絲 --- Screw M6X1.0*10 ---	1	
3		2430160400	搖動軸 --- Feed Rocker Shaft ---	1	
4		2040160500	送料台連桿 --- Feed Bar Rod ---	1	
5		ZSB16004	螺絲 --- Screw 1/4-24*16 ---	2	
6		SEN0400600	橡膠塞 --- Oil Cap ---	1	
7		2040164900	送料台軸 --- Feed Bar Shaft ---	1	
8		2040354000	油管接頭 --- Oil Pipe Joint ---	1	
9		2040160100	送料台 --- Feed Bar ---	1	
10		RE000070	E扣環 7 --- Retaining Rings- E Type 7 ---	1	
11		XP300120	油管線 --- Oil Tube ---	1	
12		ZMB05012	螺絲 --- Screw M5X0.8*9 ---	1	
13		2040161400	送料齒 --- Feed dog ---	1	
14		ZMB05004	螺絲 --- Screw M5X0.8*10 ---	1	
15		2040160800	搖動曲軸 --- Feed Rocker Shaft Crank ---	1	
16		ZMJ06004	螺絲 --- Screw M6X1.0*20 ---	1	
17		ZMA04005	螺絲 --- Screw M4X0.7*4 ---	1	
18		LG4044-0A	定環 --- Thrust Collar ---	2	
19		ZSA16029	螺絲 --- Screw 1/4-40*3.5 ---	4	
20		2040160700	搖動軸套管(後) --- Bushing, Rear ---	1	
21		ZMH06010	螺絲 --- Screw M6X1.0*10 ---	1	
22		2040170304	送料軸(結合) --- Feed Lifting Rock Shaft Com. ---	1	
23		ZMK06024	螺絲 --- Hinge Screw ---	1	
24		2040148000	滑塊 --- Slide Brock ---	1	
25		RE000040	E扣環 4 --- Retaining Rings- E Type 4 ---	1	
26		2040171800	套管 --- Bushing ---	1	
27		TC12710200	定環 --- Thrust Collar ---	1	
28		ZMH05002	螺絲 --- Screw M5X0.8*6 ---	2	
29		2040171900	套管 --- Bushing ---	1	
30		2040170104	送料土台二又 --- Feed Bar Forked Connection ---	1	
31		ZMJ06004	螺絲 --- Screw M6X1.0*20 ---	1	
32		XA200046	油線 --- Oil Wick ---	1	

H. 2040 縫目調節關係 FEED ADJUSTMENT MECHANISM COMPONENTS

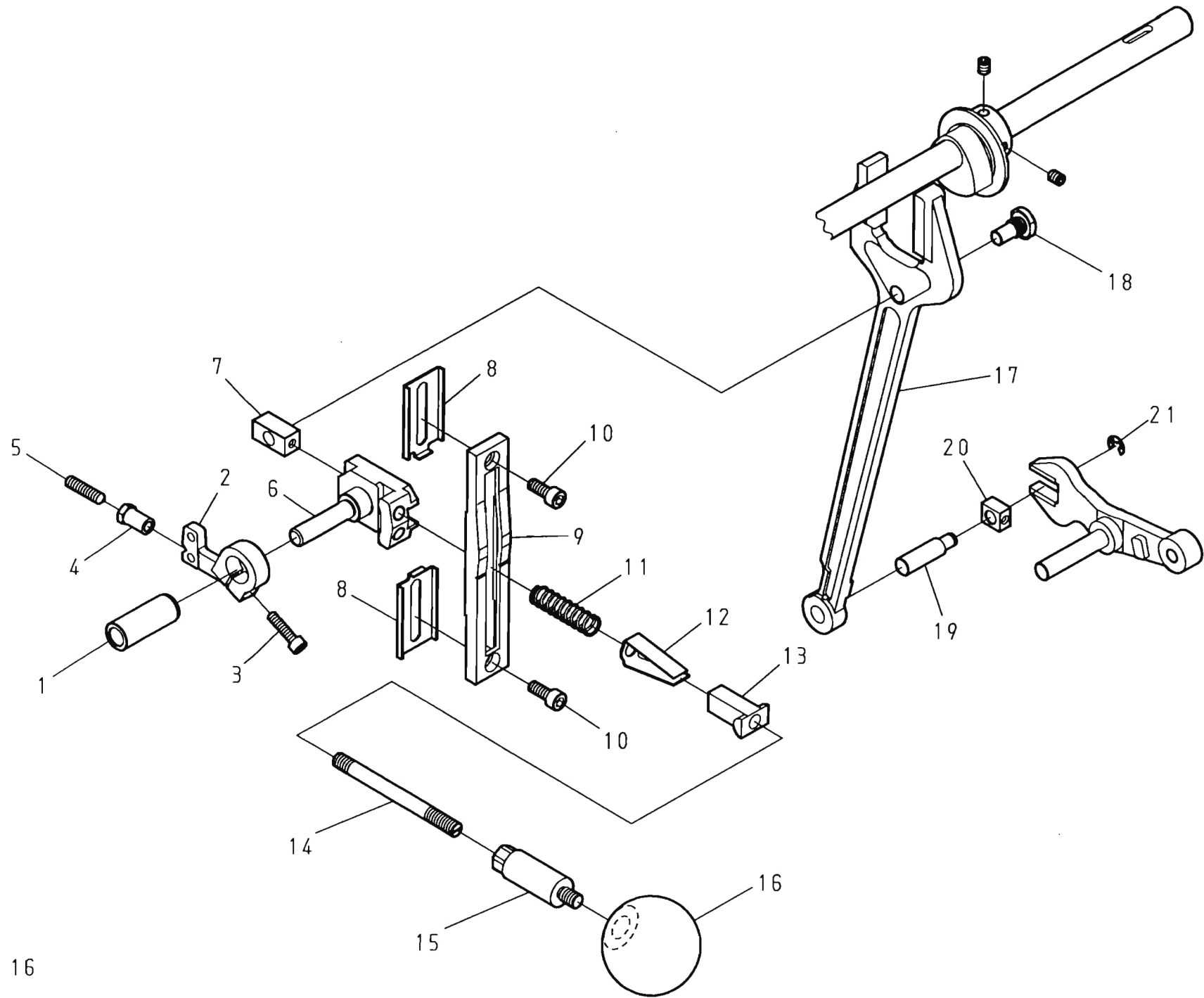

H. 2040 縫目調節關係 FEED ADJUSTMENT MECHANISM COMPONENTS

REF.No	NOTE	零件號碼 Part No.	零件名稱	Name of Part	件數 Q'TY	備註 Remarks
1		2040167900	套管	Bushing	1	
2		2040162200	送料調節桿	Feed Regulator	1	
3		ZMJ05004	螺絲	Screw M5X0.8*20	1	
4		ZMR06005	螺帽	Nut M6X1.0	1	
5		ZMH06024	螺絲	Screw M6X1.0*25	1	
6		2040161104	送料調節桿(結合)	Feed Regulator Com.	1	
7		2040167200	滑塊	Slide Brock	1	
8		2040164500	定位板	Stopper Plate	2	
9		2040161300	刻度板	Side Cover	1	
10		ZMJ06002	螺絲	Screw M6X1.0*15	2	
11		2040162000	彈簧	Spring	1	
12		2040161900	簧片	Leaf Spring	1	
13		2040162100	滑塊	Slide Brock	1	
14		2040161800	縫目調整桿	Lever Shaft	1	
15		2040161200	倒針槓桿	Lever	1	
16		4710161600	調節桿握	Lever Grip	1	
17		2040160900	連接叉桿	Rod	1	
18		ZMB10002	螺絲	Hinge Screw	1	
19		2040167600	軸	Shaft	1	
20		2040169500	滑塊	Slide Brock	1	
21		RE000050	E扣環 5	Retaining Rings- E Type 5	1	

I. 2040 下軸関係 (1/2) HOOK DRIVE SHAFT COMPONENTS (1/2)

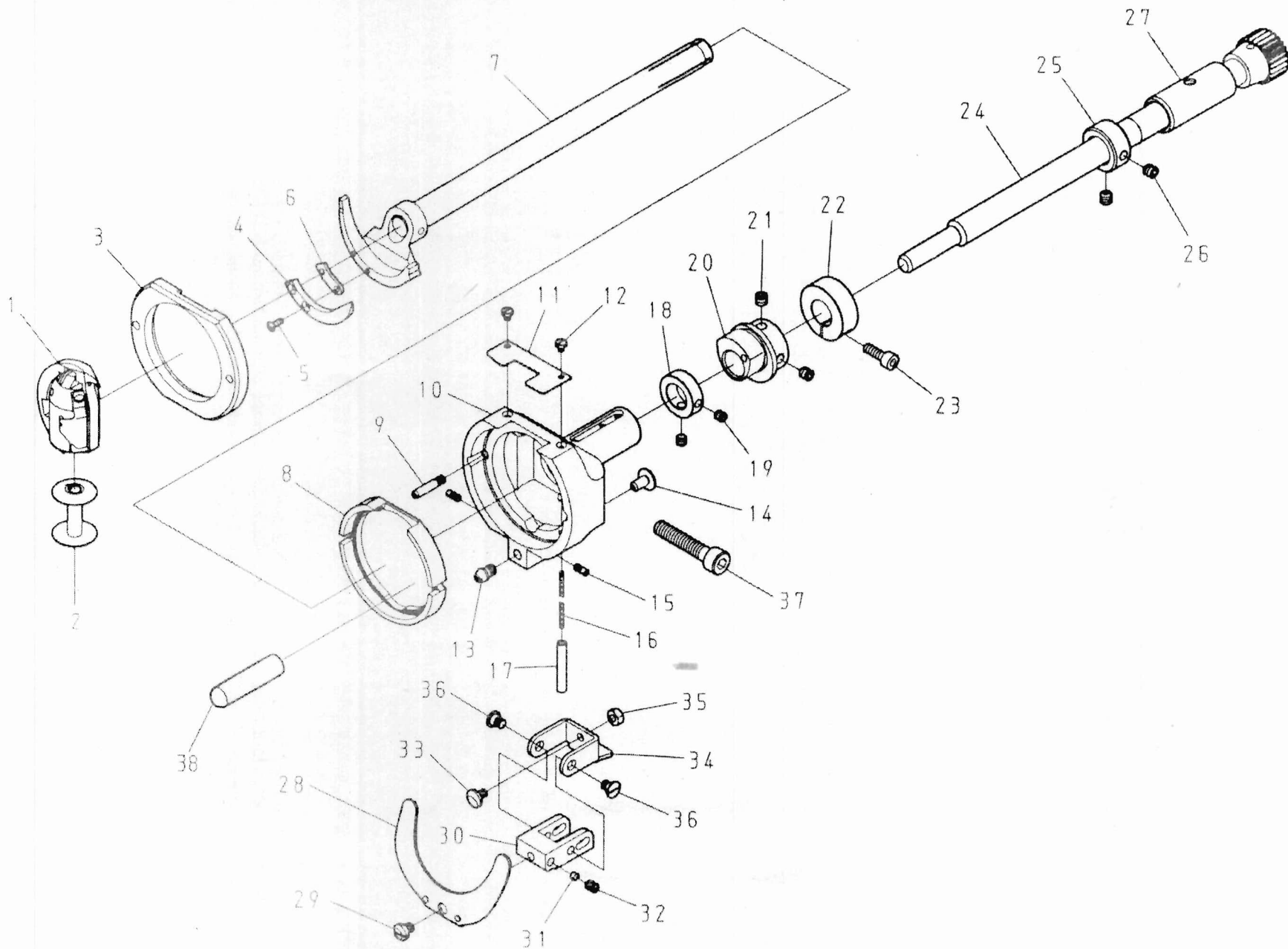

1. 2040 下軸關係 (1/2) HOOK DRIVE SHAFT COMPONENTS(1/2)

REF.No	NOTE	零件號碼 Part No.	零件名稱	Name of Part	件數 Q'TY	備註 Remarks
1		4710181300	梭頭	Hook Asm.	1	
2		4710183200	梭仔	Bobbin	1	
3		2040181400	梭頭蓋	Hook Cover	1	
4		2040189300	針寮內	Needle Guide	1	
5		ZMC03001	螺絲	Screw M3X0.5*8.5	2	
6		2040189420	定位保持板	Spacer	1	
7		2040181604	梭頭驅動柄(結合)	Shuttle Driver Com.	1	
8		2040184200	梭頭導環座	Shuttle Race Body	1	
9		ZSK11050	螺絲	Hinge Screw	2	
10		2040180300	下軸套管(左)	Bushing, Front	1	
11		2040184600	線導片	Shuttle Race Thread Guide	1	
12		ZMB03001	螺絲	Screw M3X0.5*8.5	2	
13		ZSB15055	螺絲	Screw 15/64-28*6.4	1	
14		2040184100	銷	Pin	1	
15		ZSB09091	螺絲	Screw 9/64-40*8	2	
16		XA200100	油線	Oil Wick	1	
17		XP300060	油管線	Oil Tube	1	
18		TC14708200	定環	Thrust Collar	1	
19		ZMH05001	螺絲	Screw M5X0.8*5	2	
20		2040170900	送料(偏心輪)	Feed Lifting Rock Cam	1	
21		ZMH06008	螺絲	Screw M6X1.0*6	2	
22		2040186600	繼手	Joint	1	
23		ZMJ05003	螺絲	Screw M5X0.8*15	1	
24		2040180704	齒輪(結合)	Lower Shaft Gear Com.	1	
25		TC14712200	定環	Thrust Collar	1	
26		ZMH06008	螺絲	Screw M6X1.0*6	2	
27		2040180500	下軸套管(右)	Bushing, Rear	1	
28		2040183800	簧片	Leaf Spring	1	
29		ZMB05027	螺絲	Screw M5X0.5*6.1	1	
30		2040184400	活動板	Hinge	1	
31		2040183500	銷	Pin	1	
32		ZMA05012	螺絲	Screw M5X0.5*6	1	
33		2040184500	銷	Pin	1	
34		2040184300	活動導板	Support	1	
35		ZSL11002	螺絲	Nut 11/64-40	1	
36		ZMG05023	螺絲	Hinge Screw	2	
37		ZMJ02010	螺絲	Screw M8X1.25*40	1	
38		YA040300	銷	Pin	1	

I. 2040 下軸關係 (2/2) HOOK DRIVE SHAFT COMPONENTS (2/2)

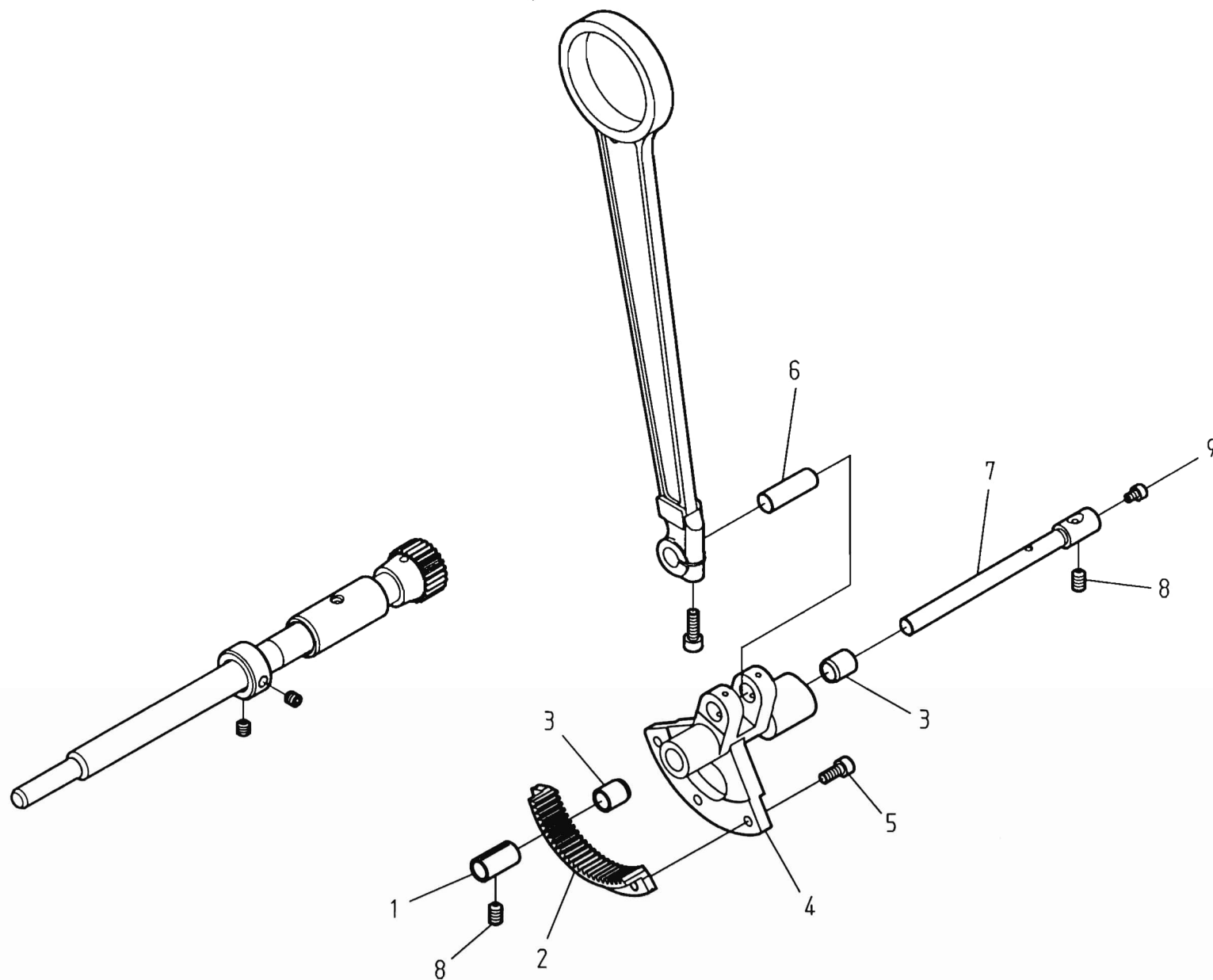

I. 2040 下軸關係 (2/2) HOOK DRIVE SHAFT COMPONENTS(2/2)

REF.No	NOTE	零件號碼 Part No.	零件名稱	Name of Part	件數 Q'TY	備註 Remarks
1		2040182400	套管	Bushing	1	
2		2040182500	齒輪	Rock Gear	1	
3		204018220A	套管	Bushing	2	
4		2040182200	搖動柄	Oscilating Rock Shaft	1	
5		ZMJ05002	螺絲	Screw M5X0.8*12	3	
6		2040183000	銷	Pin	1	
7		2040182300	軸	Shaft	1	
8		ZMH06010	螺絲	Screw M6X1.0*10	2	
9		ZMJ04008	螺絲	Screw M4X0.7*6	1	

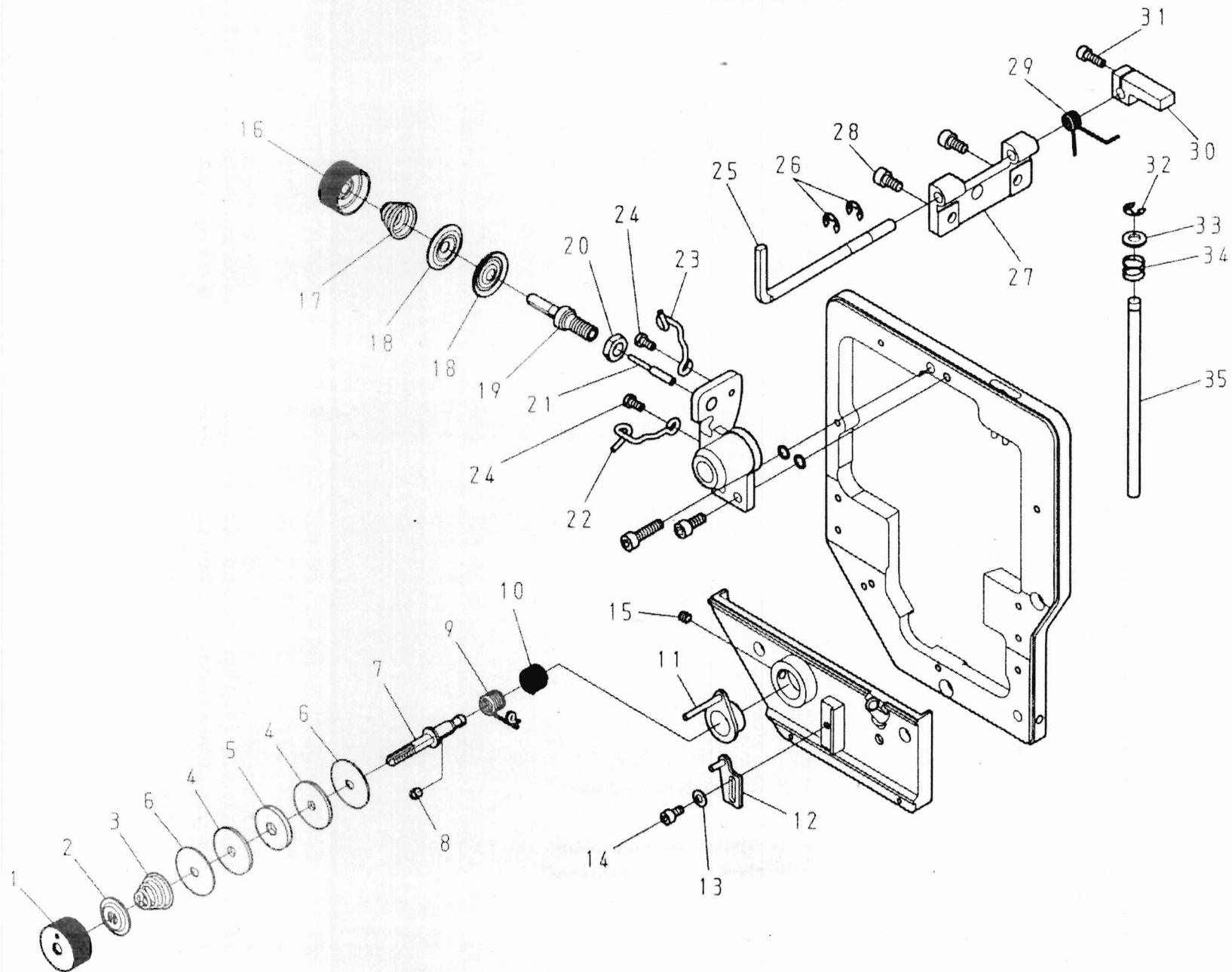

J. 2040 縫線壓力調節關係 UPPER THREAD TENSION REGULATOR MECHANISM COMPONENTS

REF.No	NOTE	零件號碼 Part No.	零件名稱	Name of Part	件數 QTY	備註 Remarks
1		2040310300	螺帽	Nut	1	
2		2040315400	線調整壓盤	Tension Regulator Presser Disk	1	
3		2040310400	調整彈簧	Thread Tension Spring	1	
4		2040311300	棉環側盤	Felt Support Plate	2	
5		2040311200	調整線輪	Thread Tension Wheel	1	
6		2040311400	棉環側盤	Felt Support Plate	2	
7		2040311100	調整螺絲桿	Thread Tension Wheel Post	1	
8		ZMH05001	螺絲	Screw M5X0.8*5	1	
9		2040310800	吊線彈簧	Spring A	1	
10		2040310900	吊線彈簧	Spring B	1	
11		2040310504	彈簧座(結合)	Thread Tension Post Bracket Com.	1	
12		2040311004	線軸彈簧調整器(結合)	Spring Support Plate Com.	1	
13		WA049003	平墊圈	Washer	1	
14		ZMJ04001	螺絲	Screw M4X0.7*8	1	
15		ZMH05001	螺絲	Screw M5X0.8*5	1	
16		2040310300	螺帽	Nut	1	
17		2040315800	調整彈簧	Thread Tension Spring	1	
18		A1025-0A	壓線盤	Tension Disk	2	
19		2040310100	調整螺絲桿	Thread Tension Post	1	
20		ZML08004	螺帽	Nut M8X1.25	1	
21		2040312000	緩線鎖	Tension Releasing Pin	1	
22		2040310600	線掛	Thread Tension Guide	1	
23		2040310610	線掛	Thread Tension Guide	1	
24		ZMB04011	螺絲	Screw M4X0.7*8	2	
25		2040317100	鬆線導板	Tension Releasing Plate	1	
26		RE000050	E扣環 5	Retaining Rings- E Type 5	2	
27		2040317000	鬆線導座	Tension Releasing Base	1	
28		ZMJ05008	螺絲	Screw M5X0.8*10	2	
29		2040312300	彈簧	Spring	1	
30		2040317500	連桿	Link	1	
31		ZMJ04005	螺絲	Screw M4X0.7*12	1	
32		RE000050	E扣環 5	Retaining Rings- E Type 5	1	
33		WA060035	平墊圈	Washer	1	
34		2040315900	彈簧	Spring	1	
35		2040317200	連接棒	Tension Releasing Bar	1	

K.

2040

附件關係

ACCESSORIES

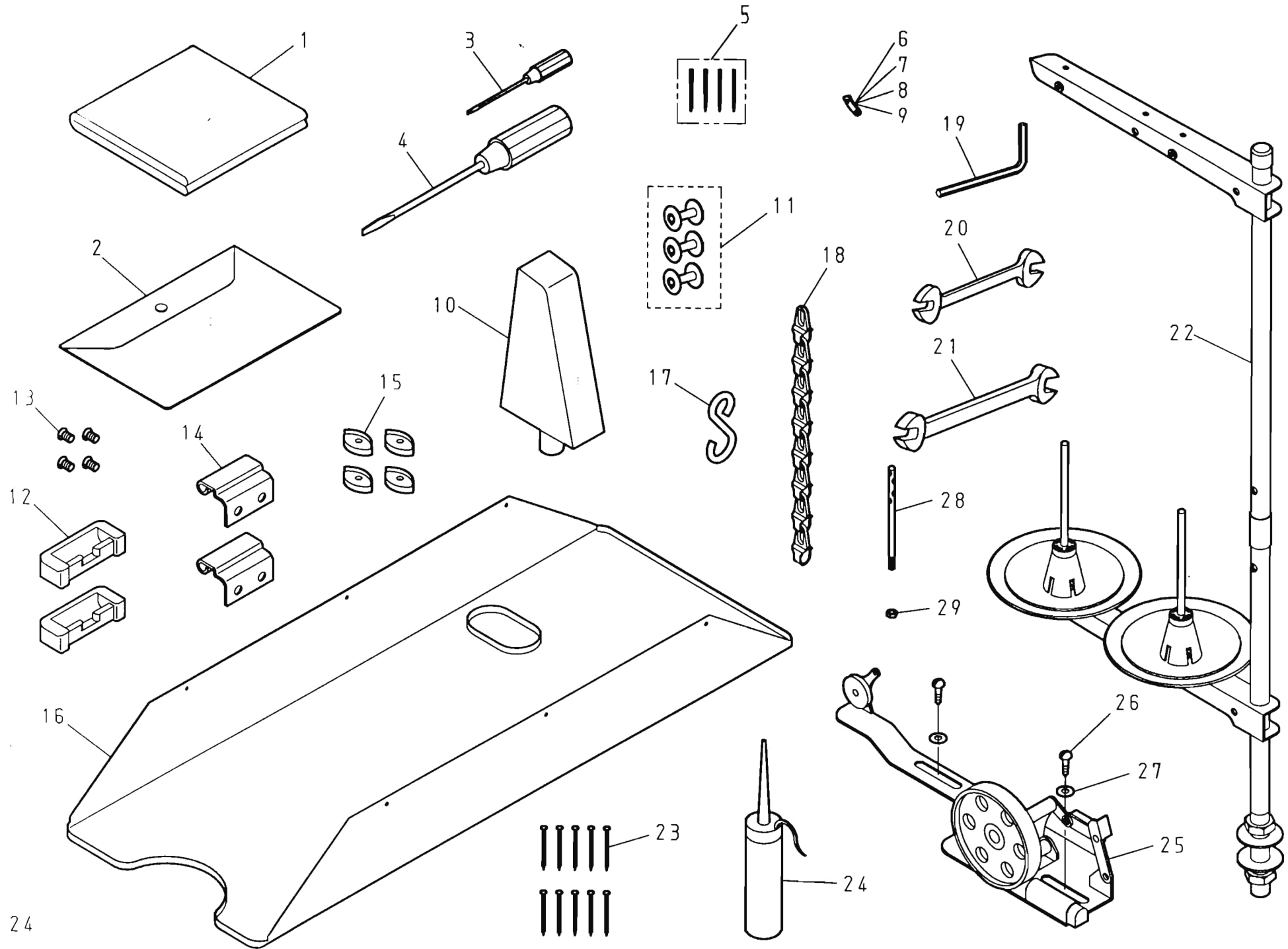

K. 2040 附件關係 ACCESSORIES

REF.No	NOTE	零件號碼 Part No.	零件名稱	Name of Part	件數 Q'TY	備註 Remarks
1		4710910900	車頭蓋	Cover	1	
2		A7000-0A	工具袋	Accessory Box	1	
3		A7010-0A	螺絲起子(小)	Screw Driver (small)	1	
4		A7010-2A	螺絲起子(大)	Screw Driver (large)	1	
5		IN794#200	針	Needle (794 Nm=200-4)	4	
6		2040189410	定位保持板	Spacer	1	
7		2040189430	定位保持板	Spacer	1	
8		2040189440	定位保持板	Spacer	1	
9		2040189450	定位保持板	Spacer	1	
10		2040119000	枕木	Arm Support	1	
11		4710183200	梭仔	Bobbin	3	
12		2040911300	後鈕座	Rubber Hinge	2	
13		ZMC08001	螺絲	Screw 9/32-28 L=9.7	4	
14		2040911700	後鈕鉤	Head Hinge	2	
15		A7026-0A	防振橡膠	Vibration Preventing Rubber	4	
16		2040912000	下油槽	Oil Pan	1	
17		4710340800	S型銷	S-Plug	2	
18		4710341400	鎖	Chain	1	
19		TLA020	六角型螺絲起子2mm	Hexagonal Wrench Key(2mm)	1	
20		TRB06×07	開口板手(6×7)	Wrench (6X7)	1	
21		TRB08×10	開口板手(8×10)	Wrench (8X10)	1	
22		J7050-0A	線架	Thread Stand	1	
23		A7011-0A	鐵釘	Nail	10	
24		A7012-1A	油壺(中)	Oiler	1	
25		2040320106	捲線器組	Bobbin Winder	1	
26		ZMT05001	木螺絲	Wood Screw L=18	2	
27		WA059003	平墊圈	Washer φ12×0.7 d=5.2	2	
28		4710113400	線柱	Needle Thread Guide Pin	1	
29		ZSL12003	螺帽	Nut 3/16-32	1	

L. 2040 皮帶蓋關係 BELT COVER COMPONENTS

REF.No	NOTE	零件號碼 Part No.	零件名稱	Name of Part	件數 Q'TY	備註 Remarks
1		2040336000	皮帶蓋土台	Belt Cover Base	1	
2		ZMJ06002	螺絲	Screw M6X1.0*15	2	
3		2040335600	皮帶蓋支持板	Belt Cover Mounting Plate	1	
4		ZMC06001	螺絲	Screw M6X1.0*16	1	
5		ZMJ06008	螺絲	Screw M6X1.0*12	1	
6		2040335300	皮帶蓋固定管	Belt Cover Stud	2	
7		ZMJ06021	螺絲	Screw M6X1.0*60	2	
8		ZML06001	螺帽	Nut M6X1.0	2	
9		ZMJ06004	螺絲	Screw M6X1.0*20	1	
10		2040335100	皮帶蓋 A	Belt Cover A	1	
11		ZMR06007	螺帽	Nut M6 × 1.0	2	
12		ZMR06006	螺帽	Nut M6 × 1.0	1	
13		2040335500	皮帶蓋 C	Belt Cover C	1	
14		2040335200	皮帶蓋 B	Belt Cover B	1	
15		ZMT04006	木螺絲	Wood Screw	4	
16		WA049006	平墊圈	Washer	4	

M. 2040 零件號碼與頁數對照表(1/3) NUMERICAL PARTS-LIST (1/3)

零件號碼 Part No.	頁數 PAGE	零件號碼 Part No.	頁數 PAGE	零件號碼 Part No.	頁數 PAGE	零件號碼 Part No.	頁數 PAGE
2040110604	11- 26	2040145420	11- 15	2040164500	17- 8	2040189410	25- 6
2040110900	3- 3	2040145430	11- 16	2040164900	15- 7	2040189420	19- 6
2040111000	3- 1	2040145440	11- 17	2040167200	17- 7	2040189430	25- 7
204011100C	3- 9	2040145450	11- 18	2040167600	17- 19	2040189440	25- 8
2040111100	3- 23	2040145460	11- 19	2040167900	17- 1	2040189450	25- 9
2040111200	3- 19	2040145470	11- 20	2040169204	9- 31	2040190104	7- 7
2040111300	3- 14	2040148000	11- 4	2040169500	17- 20	2040190210	7- 9
2040111600	3- 16	2040148000	11- 35	2040170104	15- 30	2040190220	7- 10
2040111700	3- 12	2040148000	15- 24	2040170304	15- 22	2040190230	7- 11
2040111800	3- 11	2040150100	13- 9	2040170900	19- 20	2040190240	7- 12
2040113100	3- 33	2040150200	13- 15	2040171800	15- 26	2040190250	7- 13
2040119000	25- 10	2040150400	13- 20	2040171900	15- 29	2040190260	7- 14
2040120104	5- 2	2040150500	13- 10	2040180300	19- 10	2040190270	7- 15
2040120200	5- 4	2040150604	13- 29	2040180500	19- 27	2040190300	7- 16
2040120400	5- 17	2040150704	13- 5	2040180704	19- 24	2040192100	7- 6
2040121000	7- 19	2040150804	13- 7	2040181400	19- 3	2040192300	7- 4
2040121300	5- 1	2040151000	11- 32	2040181604	19- 7	2040270100	9- 16
2040122000	5- 5	2040151100	11- 24	2040181800	5- 10	2040270200	9- 17
2040122300	5- 20	2040151700	13- 30	2040181900	5- 12	2040270400	3- 38
2040140100	7- 22	2040152500	13- 18	204018200A	5- 8	2040271100	9- 14
2040140900	7- 20	2040157104	13- 1	204018200B	5- 16	2040271300	9- 28
2040141704	11- 30	2040159900	13- 21	2040182200	21- 4	2040273000	9- 32
2040141900	9- 11	2040160100	15- 9	204018220A	21- 3	2040310100	23- 19
2040142304	9- 4	2040160500	15- 4	2040182300	21- 7	2040310300	23- 1
2040142500	11- 21	2040160600	15- 1	2040182400	21- 1	2040310300	23- 16
2040142700	11- 3	2040160700	15- 20	2040182500	21- 2	2040310400	23- 3
2040142900	11- 23	2040160800	15- 15	2040183000	21- 6	2040310504	23- 11
2040143100	9- 1	2040160900	17- 17	2040183500	19- 31	2040310600	23- 22
2040143300	11- 31	2040161104	17- 6	2040183800	19- 28	2040310610	23- 23
2040143500	13- 13	2040161200	17- 15	2040184100	19- 14	2040310800	23- 9
2040143600	11- 34	2040161300	17- 9	2040184200	19- 8	2040310900	23- 10
2040143700	11- 28	2040161400	15- 13	2040184300	19- 34	2040311004	23- 12
2040143800	13- 16	2040161800	17- 14	2040184400	19- 30	2040311100	23- 7
2040144400	5- 18	2040161900	17- 12	2040184500	19- 33	2040311200	23- 5
2040144600	11- 6	2040162000	17- 11	2040184600	19- 11	2040311300	23- 4
2040144704	11- 11	2040162100	17- 13	2040186600	19- 22	2040311400	23- 6
2040145410	11- 14	2040162200	17- 2	2040189300	19- 4	2040312000	23- 21

M. 2040 零件號碼與頁數對照表 (2/3) NUMERICAL PARTS-LIST (2/3)

零件號碼 Part No.	頁數 PAGE	零件號碼 Part No.	頁數 PAGE	零件號碼 Part No.	頁數 PAGE	零件號碼 Part No.	頁數 PAGE
2040312300	23- 29	4710181300	19- 1	TC14708200	19- 18	XP300150	3- 41
2040315400	23- 2	4710183200	19- 2	TC14712200	19- 25	YA040300	19- 38
2040315800	23- 17	4710183200	25- 11	TC16008200	11- 9	YD040014A	3- 35
2040315900	23- 34	4710340800	25- 17	TLA020	25- 19	ZMA04005	15- 17
2040317000	23- 27	4710341400	25- 18	TRB06×07	25- 20	ZMA05012	19- 32
2040317100	23- 25	4710910900	25- 1	TRB08×10	25- 21	ZMB03001	3- 13
2040317200	23- 35	A1025-0A	23- 18	WA040026	5- 15	ZMB03001	19- 12
2040317500	23- 30	A1077-0A	3- 18	WA049003	3- 26	ZMB04011	23- 24
2040320100	25- 15	A7000-0A	25- 2	WA049003	23- 13	ZMB04013	3- 32
2040333100	27- 10	A7010-0A	25- 3	WA049006	27- 16	ZMB04016	3- 25
2040335200	27- 14	A7010-2A	25- 4	WA059003	25- 27	ZMB04093	7- 24
2040335300	27- 6	A7011-0A	25- 23	WA059006	13- 4	ZMB05003	3- 15
2040335500	27- 13	A7012-1A	25- 24	WA060035	23- 33	ZMB05003	3- 17
2040335600	27- 3	A7026-0A	25- 15	WA06008	9- 5	ZMB05004	3- 20
2040335800	3- 31	BNHK0910B	7- 3	WA080007	11- 2	ZMB05004	3- 24
2040336000	27- 1	BNHK4512	5- 9	WA080022	7- 17	ZMB05004	15- 14
2040340200	13- 12	IN794#200	7- 23	WA089004	5- 21	ZMB05012	15- 12
2040340300	13- 8	IN794#200	25- 5	WH216002	5- 3	ZMB05027	19- 29
2040341700	13- 26	J7050-0A	25- 22	XA200046	15- 32	ZMB06020	5- 13
2040342300	13- 28	KC0305520	5- 7	XA200100	19- 16	ZMB08005	11- 5
2040350200	3- 21	LG4043-0A	9- 7	XA200150	3- 44	ZMB08005	11- 37
2040351504	3- 28	LG4044-0A	15- 18	XA200180	3- 43	ZMB10002	17- 18
2040351900	3- 5	RE000040	9- 30	XA200280	3- 36	ZMC03001	19- 5
2040352900	9- 24	RE000040	11- 36	XA200300	9- 19	ZMC06001	27- 4
2040353604	3- 37	RE000040	15- 25	XA200360	11- 39	ZMC08001	25- 13
2040353804	3- 40	RE000050	17- 21	XA200400	3- 30	ZMG05023	19- 36
2040353804	9- 23	RE000050	23- 26	XA200800	3- 42	ZMH05001	7- 2
2040354000	15- 8	RE000050	23- 32	XA300460	9- 27	ZMH05001	11- 10
2040912000	25- 16	RE000070	9- 2	XB130001	3- 22	ZMH05001	19- 19
2430160400	15- 3	RE000070	15- 10	XB215001	3- 27	ZMH05001	23- 8
2040911300	25- 12	RE000080	9- 15	XB400063	3- 8	ZMH05001	23- 15
2040911100	25- 14	RE000100	13- 6	XP300045	9- 22	ZMH05002	9- 29
4410142400	9- 9	SEN0400600	15- 6	XP300055	9- 26	ZMH05002	9- 34
4710113400	25- 28	TC09008200	7- 1	XP300060	19- 17	ZMH05002	15- 28
4710150300	13- 24	TC09508200	9- 20	XP300120	15- 11	ZMH05003	11- 29
4710151500	13- 25	TC10010200	9- 33	XP300100	11- 38	ZMH05006	9- 21
4710161600	17- 16	TC12710200	15- 27	XP300200	3- 29	ZMH06003	5- 6

M. 2040 零件號碼與頁數對照表(3/3) NUMERICAL PARTS-LIST (3/3)

零件號碼 Part No.	頁數 PAGE	零件號碼 Part No.	頁數 PAGE	零件號碼 Part No.	頁數 PAGE	零件號碼 Part No.	頁數 PAGE
ZMH06003	7-5	ZMJ05017	7-8	ZSD20009	9-10		
ZMH06008	3-39	ZMJ06001	3-34	ZSD20009	11-7		
ZMH06008	19-21	ZMJ06002	17-10	ZSD20011	9-12		
ZMH06008	19-26	ZMJ06002	27-2	ZSK11050	19-9		
ZMH06010	15-2	ZMJ06004	15-16	ZSL11002	19-35		
ZMH06010	15-21	ZMJ06004	15-31	ZSL12003	25-29		
ZMH06010	21-8	ZMJ06004	27-9				
ZMH06016	9-18	ZMJ06006	13-14				
ZMH06023	13-27	ZMJ06008	27-5				
ZMH06024	17-5	ZMJ06009	5-19				
ZMH08002	5-24	ZMJ06009	13-11				
ZMJ03001	3-7	ZMJ06021	27-7				
ZMJ03010	3-6	ZMJ08003	5-22				
ZMJ03010	13-19	ZMJ08006	11-1				
ZMJ04001	23-14	ZMJ08010	19-37				
ZMJ04002	11-33	ZMJ08011	5-14				
ZMJ04003	3-2	ZMK06024	15-23				
ZMJ04003	11-22	ZMK06025	9-3				
ZMJ04004	13-22	ZMK08016	9-13				
ZMJ04005	3-4	ZMK08017	11-13				
ZMJ04005	11-25	ZML04006	13-23				
ZMJ04005	13-17	ZML06001	9-6				
ZMJ04005	23-31	ZML06001	27-8				
ZMJ04008	5-11	ZML08004	7-18				
ZMJ04008	9-25	ZML08004	11-12				
ZMJ04008	21-9	ZML08004	23-20				
ZMJ04020	3-10	ZMR06005	17-4				
ZMJ05002	11-27	ZMR06006	27-12				
ZMJ05002	13-3	ZMR06007	27-11				
ZMJ05002	21-5	ZMT04006	27-15				
ZMJ05003	5-23	ZMT05001	25-26				
ZMJ05003	7-21	ZSA16010	9-8				
ZMJ05003	13-31	ZSA16020	11-8				
ZMJ05003	19-23	ZSA16029	15-19				
ZMJ05004	13-2	ZSB09091	19-15				
ZMJ05004	17-3	ZSB15055	19-13				
ZMJ05008	23-28	ZSB16004	15-5				

www.consew.com

CONSEW®

Specifications subject to change without notice

© 2023 CONSEW USA