

Since 1898
CONSEW[®]

Model 205RB-7DD-1

FULLY AUTOMATIC, DIRECT DRIVE

LARGE
BOBBIN

WITH
DIRECT DRIVE
FULLY AUTOMATIC FUNCTIONS with DISPLAY
AUTOMATIC LUBRICATION SYSTEM
MANUAL & AUTOMATIC REVERSE WITH KNUCKLE SWITCH
LARGE BOBBIN AND HORIZONTAL AXIS HOOK (SIDE LOAD)
3 S.P.I. (8 mm) STITCH LENGTH
LOCKING STITCH REGULATOR



**DIRECT DRIVE
HEAVY DUTY
SINGLE NEEDLE
DROP FEED (UPPER & LOWER FEED)
(No Needle Feed) ALTERNATING PRESSER FEET
LOCKSTITCH MACHINE**

Model 205RB-7DD-1

APPLICATIONS

- For sewing light to heavy-weight fabric, canvas, leather, vinyl, synthetics and various laminated and coated materials
- Designed for stitching such products as auto, boat and furniture upholstery, tarpaulins, covers, awnings, tents, handbags, luggage, sports and camping equipment, outdoor clothing, footwear, orthopedic appliances, ballistic armor, parachute containers, etc.

FEATURES

- Direct Drive Motor (*no belt connection required*)
- Large bobbin and horizontal axis hook (*side load*)
- Drop feed (upper & lower feed) alternating presser feet
- Fully automatic functions including automatic electric foot lift
- Automatic lubrication system
- **New:** Top thread electric clamping system for trimming
- Automatic Thread Trim Function
- Built-in bobbin winder
- Locking stitch regulator
- Safety-type handwheel
- Stitch length indicator on outside of machine
- All sizes of cording feet available
- Standard presser feet fittings
- Standard attachments easily installed
- Convenient half stitch & jog switch
- Built-in LED light

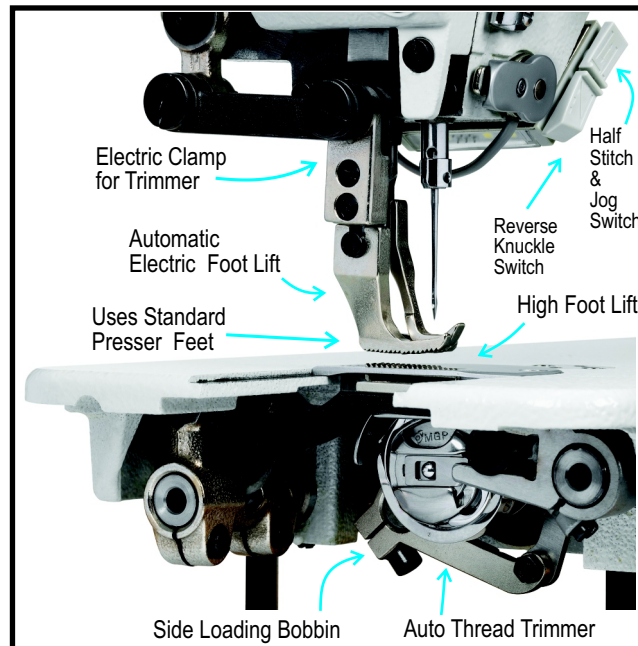

Simple Trim Mechanism

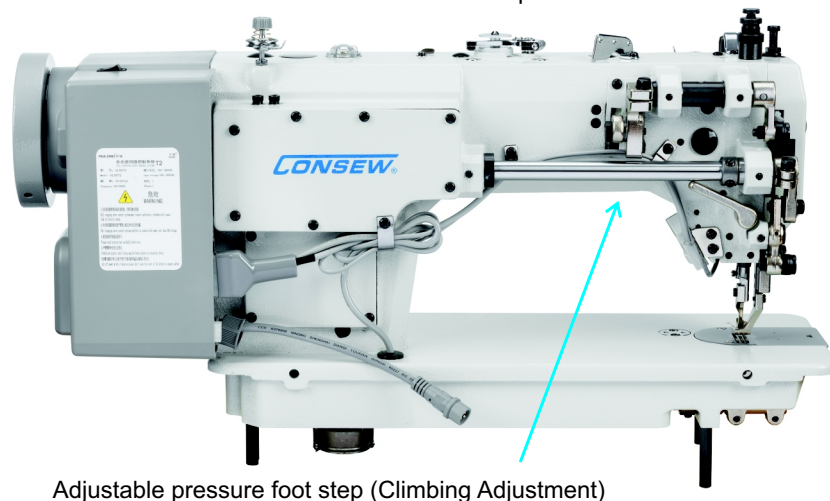

SPECIFICATIONS

205RB-7DD-1

Speed, Max. (S.P.M.)	2000 *
Stitch Length, Max.	3 s.p.i. (8 mm)
Needle	DP x 17 23#
Needle bar Stroke	37 mm
Presser	by hand 8 mm
Foot Lift	by knee 16 mm
Stitch Type	301
Motor	750 watt servo motor
Power	110 v / 220 v

* Speed depends on thread, material and operation.