

Since 1898
CONSEW[®]

Model 205RB-7DD-1

FULLY AUTOMATIC, DIRECT DRIVE

220V only. Optional 110V/220V converter can be purchased separately.

WITH

DIRECT DRIVE

FULLY AUTOMATIC FUNCTIONS with DISPLAY

AUTOMATIC LUBRICATION SYSTEM

REVERSE KNUCKLE SWITCH

LARGE BOBBIN AND HORIZONTAL AXIS HOOK (SIDE LOAD)

3 S.P.I. (8 mm) STITCH LENGTH

DIGITAL STITCH REGULATOR

STANDARD PRESSER FEET FITTINGS

**LARGE
BOBBIN**



**DIRECT DRIVE
HEAVY DUTY
SINGLE NEEDLE
DROP FEED (UPPER & LOWER FEED)
ALTERNATING PRESSER FEET
LOCKSTITCH MACHINE**

Model 205RB-7DD-1

APPLICATIONS

- For sewing light to heavy-weight fabric, canvas, leather, vinyl, synthetics and various laminated and coated materials
- Designed for stitching such products as auto, boat and furniture upholstery, tarpaulins, covers, awnings, tents, handbags, luggage, sports and camping equipment, outdoor clothing, footwear, orthopedic appliances, ballistic armor, parachute containers, etc.

FEATURES

- Direct Drive Motor (*no belt connection required*)
- Power required: 220V.
Optional 110V/220V converter can be purchased separately.
- Large bobbin and horizontal axis hook (*side load*)
- Drop feed (upper & lower feed) alternating presser feet
- Fully automatic functions including automatic electric foot lift
- Automatic lubrication system
- **New:** Top thread electric clamping system for trimming
- Automatic Thread Trim Function
- Built-in bobbin winder
- Digital Stitch Length Control
- Assorted sizes of cording feet available
- Standard presser feet fittings
- Standard attachments easily installed
- Convenient half stitch & jog switch
- Built-in LED light
- Handwheel

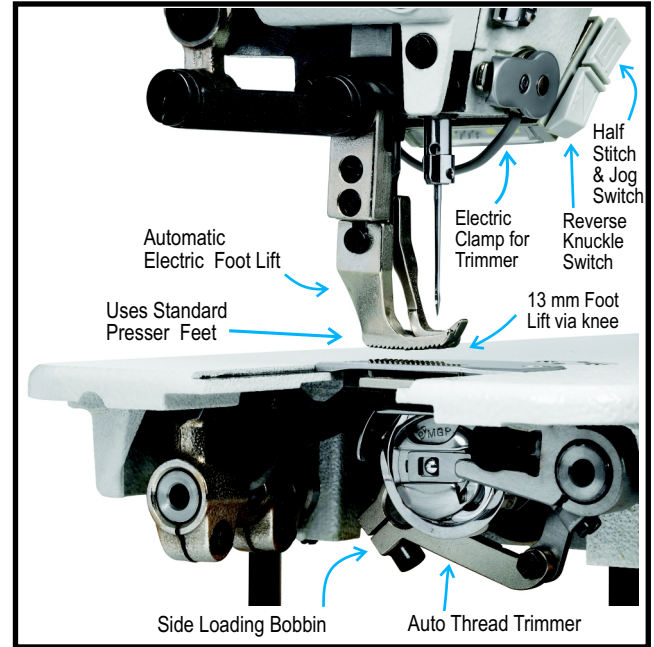

Simple Trim Mechanism

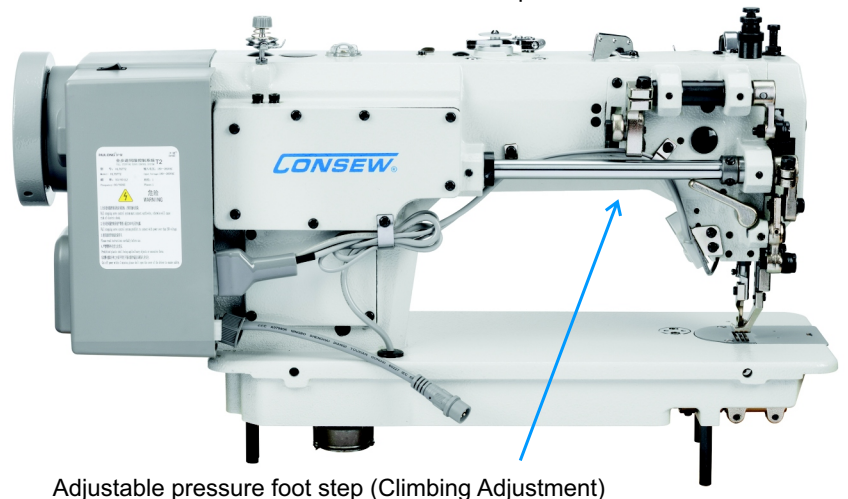

Adjustable pressure foot step (Climbing Adjustment)

SPECIFICATIONS

205RB-7DD-1

Speed, Max. (S.P.M.)	2200 *
Stitch Length, Max.	3 s.p.i. (8 mm)
Needle	135X17 sizes 18-23
Presser by hand	6 mm
Foot Lift by knee	13 mm
Stitch Type	301
Motor	750W servo motor
Power	220V
* Speed depends on thread, material and operation.	