

Since 1898  
**CONSEW**<sup>®</sup>

# Model 205RB-7DD-1

## FULLY AUTOMATIC, DIRECT DRIVE

Comes in 220v. only

Optional 110V/220V converter can be purchased separately.

WITH  
DIRECT DRIVE  
FULLY AUTOMATIC FUNCTIONS with DISPLAY  
AUTOMATIC LUBRICATION SYSTEM  
MANUAL & AUTOMATIC REVERSE WITH KNUCKLE SWITCH  
LARGE BOBBIN AND HORIZONTAL AXIS HOOK (SIDE LOAD)  
3 S.P.I. (8 mm) STITCH LENGTH  
LOCKING STITCH REGULATOR  
STANDARD PRESSER FEET FITTINGS

**LARGE  
BOBBIN**



**DIRECT DRIVE  
HEAVY DUTY  
SINGLE NEEDLE**

**DROP FEED (UPPER & LOWER FEED)  
ALTERNATING PRESSER FEET  
LOCKSTITCH MACHINE**

(No Needle Feed)

# Model 205RB-7DD-1

## APPLICATIONS

- For sewing light to heavy-weight fabric, canvas, leather, vinyl, synthetics and various laminated and coated materials
- Designed for stitching such products as auto, boat and furniture upholstery, tarpaulins, covers, awnings, tents, handbags, luggage, sports and camping equipment, outdoor clothing, footwear, orthopedic appliances, ballistic armor, parachute containers, etc.

## FEATURES

- Direct Drive Motor (*no belt connection required*)
- Power required: 220V.  
*Optional 110V/220V converter can be purchased separately.*
- Large bobbin and horizontal axis hook (*side load*)
- Drop feed (upper & lower feed) alternating presser feet
- Fully automatic functions including automatic electric foot lift
- Automatic lubrication system
- **New:** Top thread electric clamping system for trimming
- Automatic Thread Trim Function
- Built-in bobbin winder • Locking stitch regulator
- Safety-type handwheel
- Stitch length indicator on outside of machine
- All sizes of cording feet available
- Standard presser feet fittings
- Standard attachments easily installed
- Convenient half stitch & jog switch
- Built-in LED light

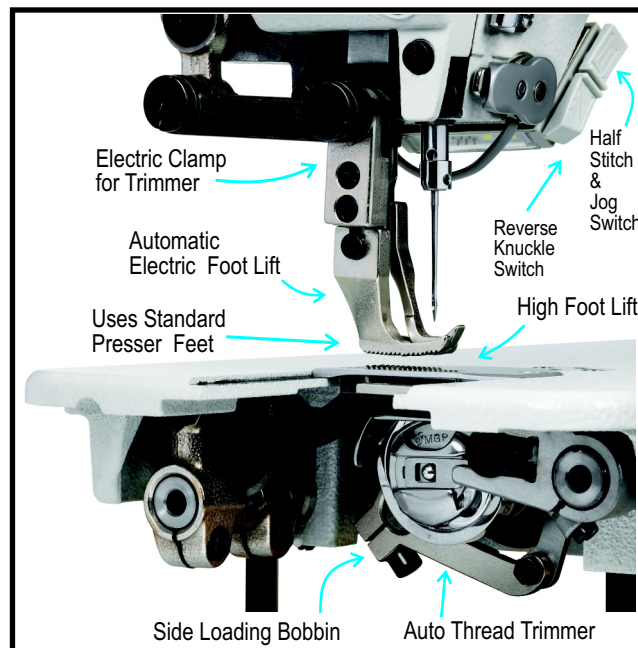

Simple Trim Mechanism

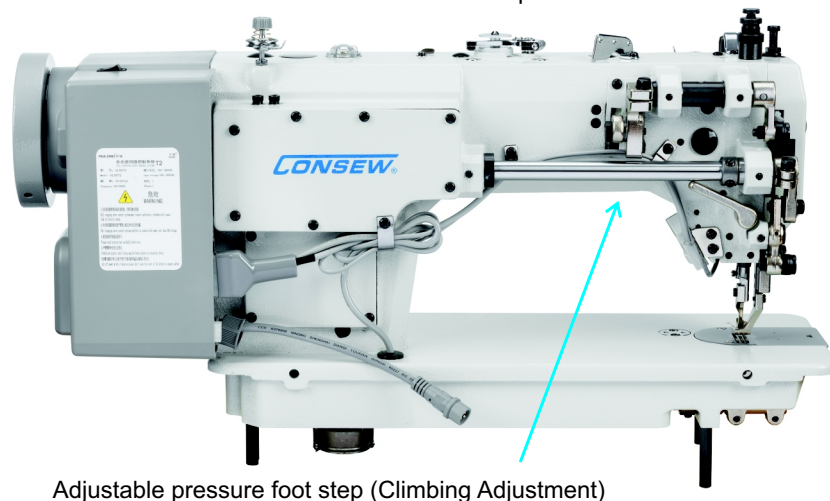

## SPECIFICATIONS

### 205RB-7DD-1

Speed, Max. (S.P.M.)	2000 *
Stitch Length, Max.	3 s.p.i. (8 mm)
Needle	DP x 17 23#
Needle bar Stroke	37 mm
Presser	by hand 8 mm
Foot Lift	by knee 16 mm
Stitch Type	301
Motor	750 watt servo motor
Power	110 v / 220 v
* Speed depends on thread, material and operation.	